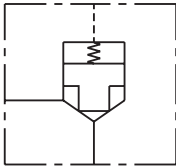
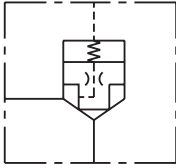
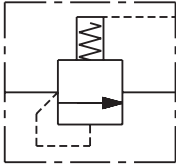
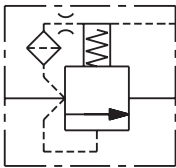
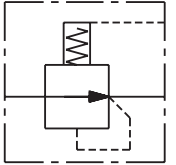
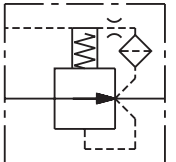

	SERIES	CAVITY	DESCRIPTION	FLOW LPM/GPM	PRESSURE BAR/PSI	PAGE NO.
	<b>POPPET TYPE</b>					
	10SLC1-A	C10-3S	Normally Closed, Pilot to Close	57/15	240/3500	LE7
	16SLC1-A	C16-3S	Normally Closed, Pilot to Close	189/50	240/3500	LE8
	20SLC1-A	C20-3S	Normally Closed, Pilot to Close	303/80	240/3500	LE9
	16SLC1-C	C16-3S	Normally Closed, Vent to Open	189/50	240/3500	LE10
	<b>SPOOL TYPE</b>					
	10SLC2-A	C10-3S	Normally Closed, Pilot to Close	57/15	240/3500	LE11
	16SLC2-A	C16-3S	Normally Closed, Pilot to Close	189/50	240/3500	LE12
	20SLC2-A	C20-3S	Normally Closed, Pilot to Close	303/80	240/3500	LE13
	R04E3	C10-3S	Normally Closed, Pilot to Close	170/45	420/6000	LE14
	R06E3	C16-3S	Normally Closed, Pilot to Close	400/106	420/6000	LE15
	R08E3	C20-3S	Normally Closed, Pilot to Close	500/132	420/6000	LE16
	10SLC2-B	C10-3S	Normally Closed, Vent to Open	57/15	240/3500	LE17
	16SLC2-B	C16-3S	Normally Closed, Vent to Open	189/50	240/3500	LE18
	20SLC2-B	C20-3S	Normally Closed, Vent to Open	303/80	240/3500	LE19
	R04F3	C10-3S	Normally Closed, Vent to Open	170/45	420/6000	LE20
	R06F3	C16-3S	Normally Closed, Vent to Open	400/106	420/6000	LE21
	R08F3	C20-3S	Normally Closed, Vent to Open	500/132	420/6000	LE22
	10SLC3-A	C10-3S	Normally Open, Vent to Close	57/15	240/3500	LE23
	16SLC3-A	C16-3S	Normally Open, Vent to Close	189/50	240/3500	LE24
	R04H3	C10-3S	Normally Open, Vent to Close	57/15	420/6000	LE25
	R06H3	C16-3S	Normally Open, Vent to Close	160/42	420/6000	LE26
	10SLC3-B	C10-3S	Normally Open, Vent to Close	57/15	240/3500	LE27
	16SLC3-B	C16-3S	Normally Open, Vent to Close	189/50	240/3500	LE28
	R04G3	C10-3S	Normally Open, Vent to Close	57/15	420/6000	LE29
	R06G3	C16-3S	Normally Open, Vent to Close	160/42	420/6000	LE30

- CV**  
Check Valves
- SH**  
Shuttle Valves
- LM**  
Load/Motor Controls
- FC**  
Flow Controls
- PC**  
Pressure Controls
- LE**  
Logic Elements
- DC**  
Directional Controls
- MV**  
Manual Valves
- SV**  
Solenoid Valves
- PV**  
Proportional Valves
- CE**  
Coils & Electronics
- BC**  
Bodies & Cavities
- TD**  
Technical Data

- CV Check Valves
- SH Shuttle Valves
- LM Load/Motor Controls
- FC Flow Controls
- PC Pressure Controls
- LE Logic Elements
- DC Directional Controls
- MV Manual Valves
- SV Solenoid Valves
- PV Proportional Valves
- CE Coils & Electronics
- BC Bodies & Cavities
- TD Technical Data

**INTRODUCTION:**

Parker's logic valves offer system designers a versatile range of screw-in elements that, when used in the proper combinations, can provide flexible design solutions for many common cartridge valve applications. They offer system designers the advantage of applying cartridge valve technology in applications where the flow and pressure conditions may exceed the limits of typical cartridge valves. Logic valves are essentially high flow poppet or spool elements that are controlled by small pilot devices. They can be used to control flow, pressure, or direction, and when applied in the proper arrangements, can perform multi-task control functions. Parker's logic valves offer system designers alternative products that can help reduce the size, cost, and complexity of integrated manifold systems.

**NEW PRODUCTS:**

Parker Logic Valves are offered in two basic categories: Poppet and Spool.

**Now Available in  
6000 PSI**

**Poppet Type** - Used for flow switching directional control applications.

**Spool Type** - Used for pressure sensing in modulating applications to regulate flow and pressure.

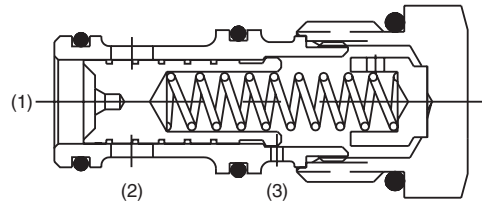
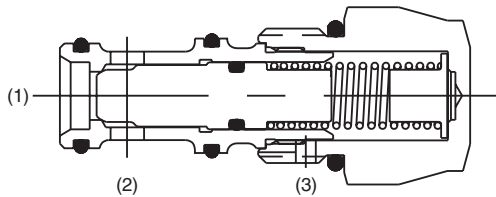

**PRODUCT TYPES / APPLICATIONS  
POPPET TYPE**

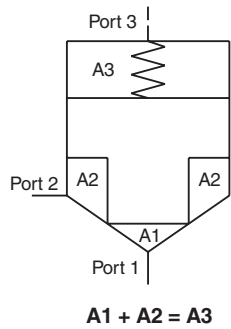

Poppet type logic valves are 3 ported, 2-way on/off valves that switch flow between port 1 and port 2. The poppet's on/off action is operated by controlling pilot oil at port 3 of the valve. A small low flow solenoid or pilot valve is an ideal control for this purpose. Parker offers vent-to-open and pilot-to-close style poppet logic valves.

**Note:** Poppet logic valves are an unbalanced 2:1 ratio poppet design. The opening and closing of the poppet is dependent on the force balances on the areas of the poppet at port 1, port 2, and port 3.

**Vent-to-open logic valves:**

Vent-to-open logic valves are primarily used for uni-directional flow switching applications. The poppet in the vent-to-open logic valve is spring biased to the closed condition. The pilot oil source that operates the logic element is generated internally by direct pressure from either work port 1 or 2, depending on the option chosen. Venting the pilot oil at port 3 allows the valve to open and pass flow between port 1 and port 2 at the bias spring setting. Blocking the pilot at port 3 causes the valve to close. When closed, the 2:1 ratio poppet design provides a positive low leak seal. Because the pilot source is generated internally within the valve, vent-to-open logic valves are best suited for uni-directional applications.

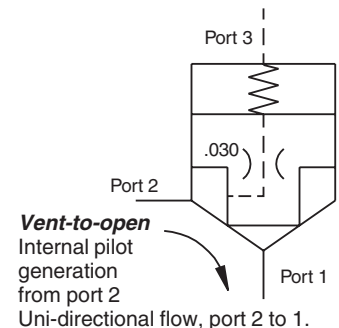
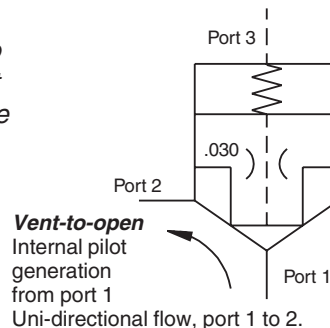

**POPPET TYPE** *Continued*

**Pilot-to-close logic valve:**

Pilot-to-close logic elements are primarily used for bi-directional flow switching applications. The poppet in the pilot-to-close logic valve is spring biased to the closed condition. With no pilot signal at port 3, the valve will open allowing flow in either direction between work ports 1 and 2 once pressure at one of the work ports reaches the biased spring setting. Applying a sufficient externally generated pilot force to port 3 of the valve closes the poppet creating a low leak seal between port 1 and port 2.

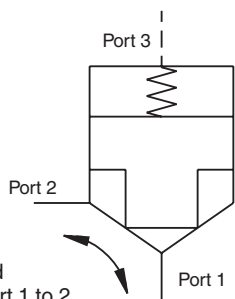

**Pilot-to-close**  
External pilot required  
Bi-directional flow, port 1 to 2.

**2-way, 3-way, and 4-way Directional Control:**

Poppet logic valves are typically used to perform high flow directional switching operations using small low power pilot valves to control the sequence of the directional operation.

- A single logic valve can be used to control 2-way, on/off switching.
- Multiple elements in a bridge arrangement can control 3-way or 4-way directional switching.
- Since each logic valve is individually controlled, the timing, sequence, and overlap of directional functions can be controlled very precisely.
- Uni-directional or bi-directional flow can be achieved, depending on the valve selected.
- Flows in excess of 80 gpm can be controlled through a single logic element, and more than one logic valve can be used in parallel to control flow in excess of the rated flow of a single element.
- Poppet construction provides a low leak directional control.

(See circuit examples on pages LE4-LE5)

**SPOOL TYPE**

Spool type logic valves can also be used for directional switching, however, they are typically used in modulating applications to control flow or regulate pressure. Virtually any pressure or flow control function can be achieved with a spool type logic valve including; restrictive or priority flow control, pressure relief, pressure reducing, sequencing, and unloading.

The spools in this category of logic valves are balanced designs; the spool area at the work port (port 1) and the pilot port (port 3) are equal (1:1). The spool is held in a biased condition by a spring. Venting the pilot at port 3 creates an unbalanced condition causing the valve spool to modulate open or close, depending on the valve chosen. This spool design makes the valve vary stable because the forces acting to open and close the valve are in balance.

**Flow Control / Compensators:**

Parker offers two types of logic valves for flow control functions.

- 1) Normally open spools function as a restrictive type compensator.
- 2) Normally closed spools function as a priority or by-pass compensator.

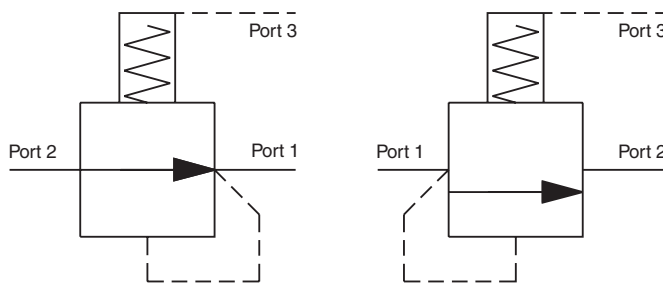

**Normally open spool**

**Normally closed spool**

<b>CV</b>
Check Valves
<b>SH</b>
Shuttle Valves
<b>LM</b>
Load/Motor Controls
<b>FC</b>
Flow Controls
<b>PC</b>
Pressure Controls
<b>LE</b>
Logic Elements
<b>DC</b>
Directional Controls
<b>MV</b>
Manual Valves
<b>SV</b>
Solenoid Valves
<b>PV</b>
Proportional Valves
<b>CE</b>
Coils & Electronics
<b>BC</b>
Bodies & Cavities
<b>TD</b>
Technical Data

- CV** Check Valves
- SH** Shuttle Valves
- LM** Load/Motor Controls
- FC** Flow Controls
- PC** Pressure Controls
- LE** Logic Elements
- DC** Directional Controls
- MV** Manual Valves
- SV** Solenoid Valves
- PV** Proportional Valves
- CE** Coils & Electronics
- BC** Bodies & Cavities
- TD** Technical Data

**Restrictive Flow Regulator:**

Normally open spool type logic elements can be used with an external orifice or valve as a compensator to regulate flow. Used as restrictive compensator, a normally open spool senses the upstream and downstream pressure across an orifice or valve. The spool modulates closed to maintain a constant pressure drop across the controlled device equal to the bias spring in the logic valve, thus maintaining a constant flow rate regardless of changes in upstream or downstream pressure.

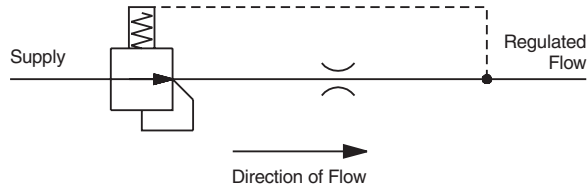

**Priority / Bypass Flow Regulator:**

A logic valve with a normally closed spool can be used as a priority or by-pass compensator. In this case, the spool modulates open to maintain a constant pressure drop across the controlled orifice or valve, thereby maintaining a constant priority flow regardless of upstream or downstream pressure changes. In a priority arrangement, any oil that doesn't saturate the controlled device is by-passed at load pressure plus the value of the bias spring in the logic valve.

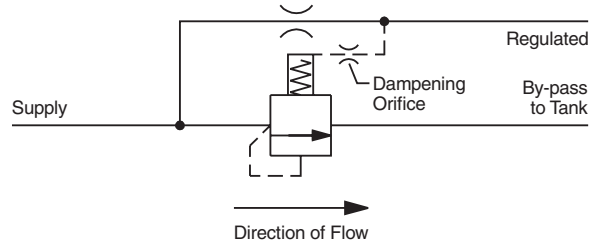

**Pressure Control:**

Spool type logic valves can be used as the main stage spool in high flow pressure control applications with the logic valve handling the high flow, and a small pilot valve controlling the action of the logic valve spool. Normally open, and normally closed spool options are available enabling virtually all pressure control functions to be achieved. When used in pressure control applications, the logic valve spool modulates open or closed to maintain the pressure setting of the pilot valve communicated to port 3. Pressure control applications require a pilot connection between the control port (port 1 or 2), and the pilot port (port 3). In order to simplify the design, Parker offers spool type logic valves with internal piloting options that can help minimize the number of connections needed. When used in manifold systems, the internal piloting options help to simplify the manifold design by reducing the number of construction drillings in the block. Multiple functions such as relief, pump unloading, and pressure compensation can be performed with one logic valve by communicating multiple pilot devices to the same logic element.

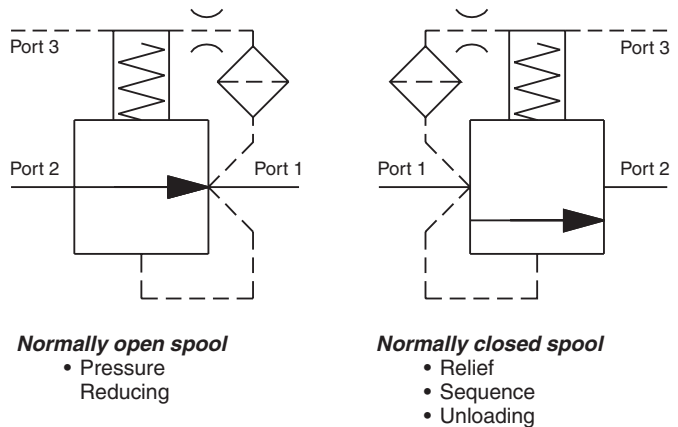

(See circuit examples on page LE6)

**Application Note:**

This section is as an application guide, and it is intended to illustrate the various ways that logic elements can be used to create a variety of hydraulic control functions. For additional help applying logic valves, contact your Parker Sales Engineer.

**DIRECTIONAL CONTROL EXAMPLES**

**2-position, 2-way normally open example.**

Switched by 2-position, 3-way pilot valve and external pilot pressure.

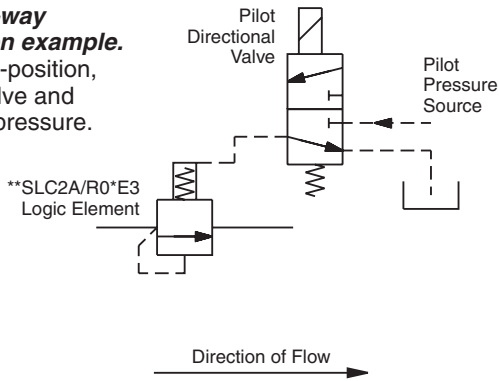

**2-position, 2-way normally open example.**

Switched by external pilot pressure and vented through 2-position, 2-way pilot valve.

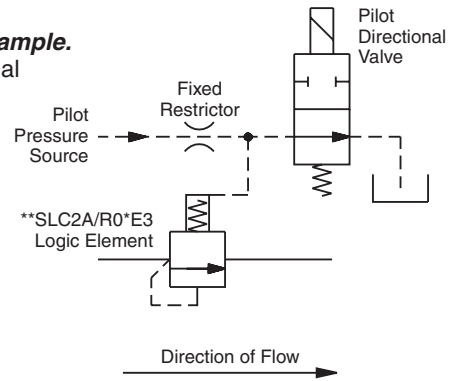

**2-position, 2-way normally open example.**

Internal pilot generation.

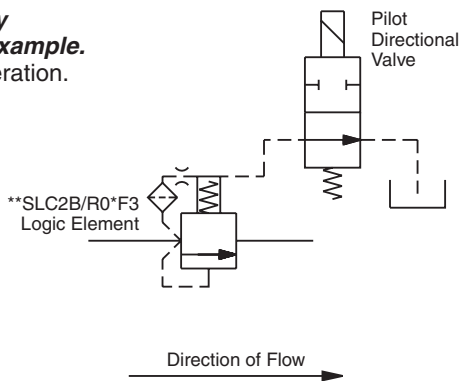

**2-position, 2-way normally open example.**

Internal pilot generation.

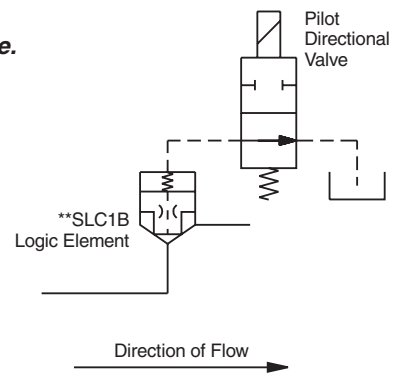

**2-position, 2-way normally open example.**

Internal pilot generation.

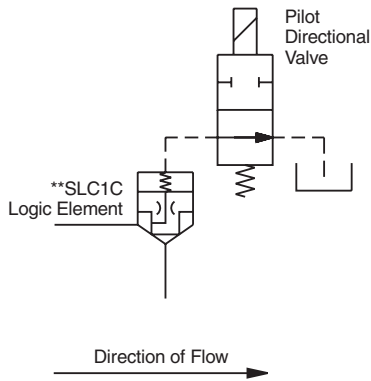

**2-position, 2-way normally open example.**

Switched by 2-position, 3-way pilot valve and external pilot.

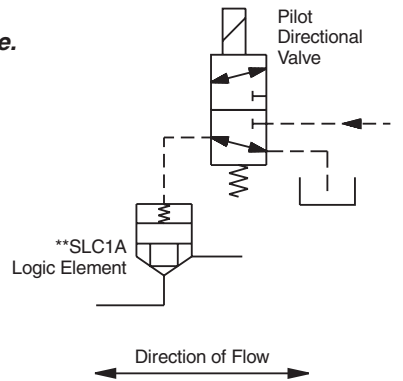

**\*\*SLC1A logic element.**

With shuttle-selected pilot supply.

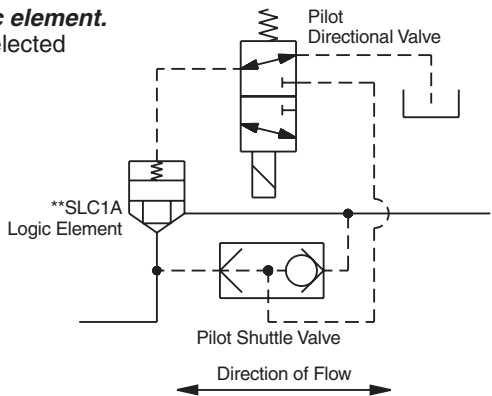

**\*\*SLC1A logic element.**

External pilot supply and 2-position, 2-way pilot directional valve.

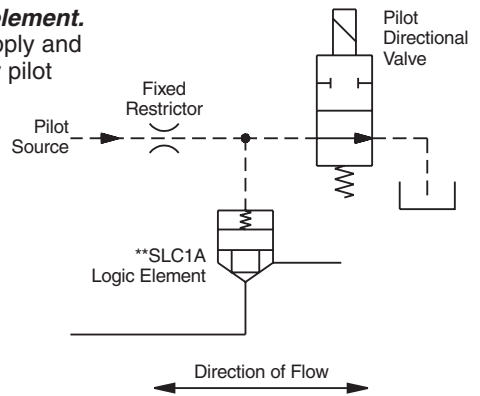

<b>CV</b>
Check Valves
<b>SH</b>
Shuttle Valves
<b>LM</b>
Load/Motor Controls
<b>FC</b>
Flow Controls
<b>PC</b>
Pressure Controls
<b>LE</b>
Logic Elements
<b>DC</b>
Directional Controls
<b>MV</b>
Manual Valves
<b>SV</b>
Solenoid Valves
<b>PV</b>
Proportional Valves
<b>CE</b>
Coils & Electronics
<b>BC</b>
Bodies & Cavities
<b>TD</b>
Technical Data

**DIRECTIONAL CONTROL EXAMPLES**

**THREE-WAY BRIDGE CIRCUITS**

*Circuit 1, with \*\*SLC1A poppet logic element.*

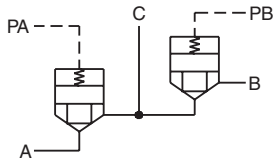

*Circuit 2, with \*\*SLC2A/R0\*E3 spool logic element.*

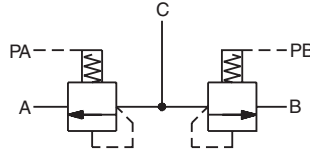

*Circuit 3, with \*\*SLC2A/R0\*E3 spool logic element.*

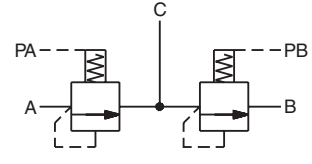

Required Flow Path	Pilot Pressure Applied To		Available From Circuit			Required Flow Path	Pilot Pressure Applied To		Available From Circuit		
	PA	PB	1	2	3		PA	PB	1	2	3
	NO	NO	X	X			NO	YES	X	X	
	YES	NO	X	X	X		NO	YES	X		X

**NOTE:** Pilot pressure must exceed load pressure in order for valve to close.

**FOUR-WAY BRIDGE CIRCUITS**

*Circuit 1, with \*\*SLC1A poppet logic elements.*

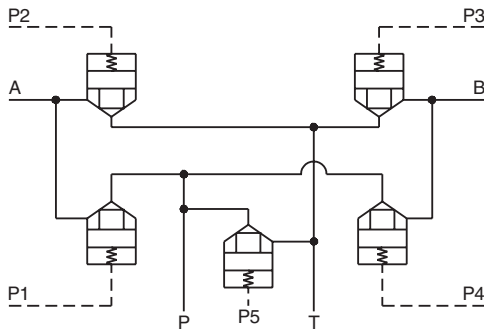

*Circuit 2, with \*\*SLC2A/R0\*E3 spool logic elements.*

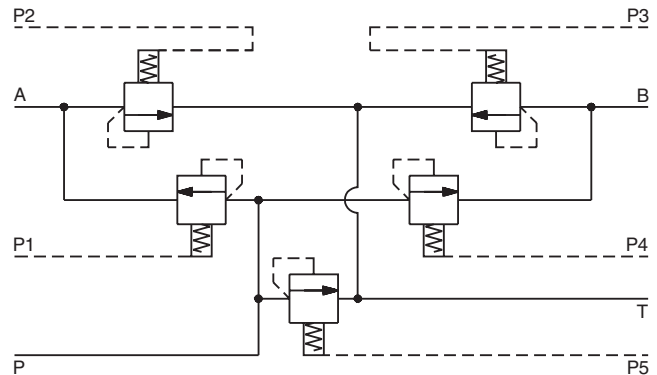

Required Flow Path	Pilot Pressure Applied To					Required Flow Path	Pilot Pressure Applied To					Required Flow Path	Pilot Pressure Applied To				
	P1	P2	P3	P4	P5		P1	P2	P3	P4	P5		P1	P2	P3	P4	P5
	YES	YES	YES	YES	YES		YES	NO	NO	YES	YES		YES	NO	YES	NO	YES
	NO	NO	NO	NO	NO		NO	YES	YES	NO	YES		YES	YES	YES	NO	YES
	YES	YES	NO	NO	NO		YES	YES	NO	YES	YES		YES	NO	YES	YES	YES
	NO	NO	YES	YES	NO		NO	YES	YES	YES	YES						
	YES	YES	YES	YES	NO		NO	YES	NO	YES	YES						

**NOTE:** Pilot pressure must exceed load pressure in order for valve to close.

- CV** Check Valves
- SH** Shuttle Valves
- LM** Load/Motor Controls
- FC** Flow Controls
- PC** Pressure Controls
- LE** Logic Elements
- DC** Directional Controls
- MV** Manual Valves
- SV** Solenoid Valves
- PV** Proportional Valves
- CE** Coils & Electronics
- BC** Bodies & Cavities
- TD** Technical Data

**FLOW CONTROL EXAMPLES**

**Pressure compensated priority flow control example.**

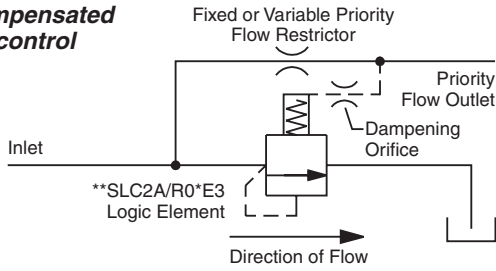

**Pressure compensated restrictive flow control example.**

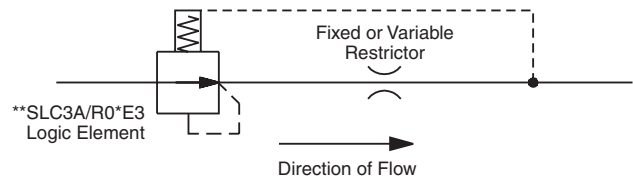

**Load sensing priority flow control example with pressure limiting and unloading.**

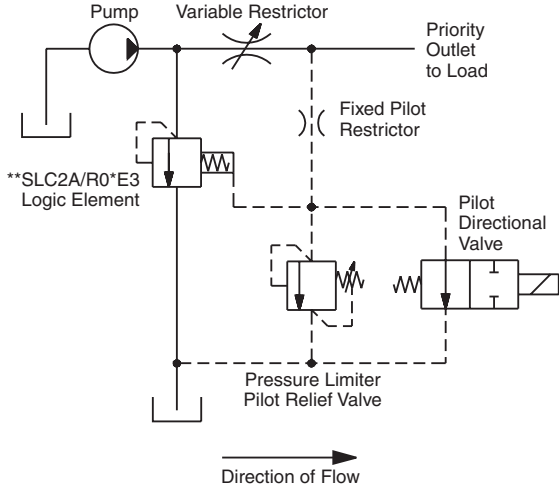

**Load sensing priority flow control example with pressure limiter.**

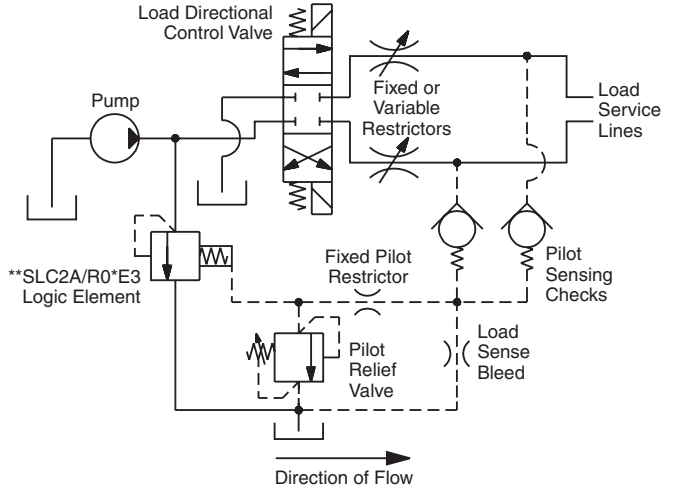

**PRESSURE CONTROL EXAMPLES**

**Pressure relief or sequence example with external pilot supply and pilot relief.**

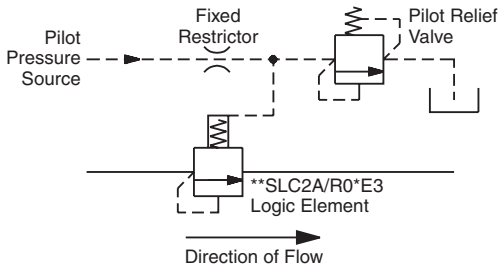

**Pressure relief or sequence example with internal pilot supply and pilot relief.**

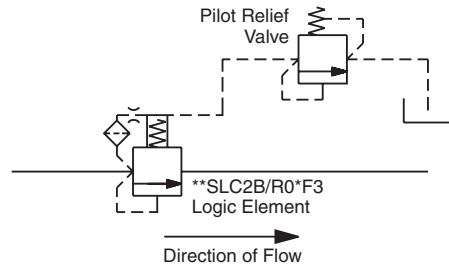

**Pressure reducing example, non-relieving type.**

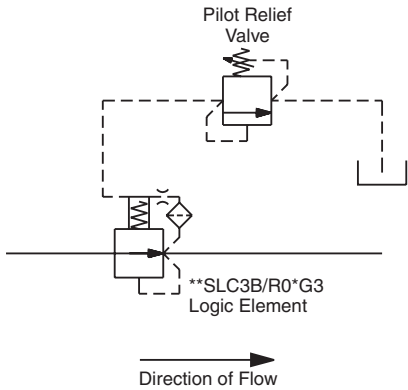

**Pressure reducing-relieving example.**

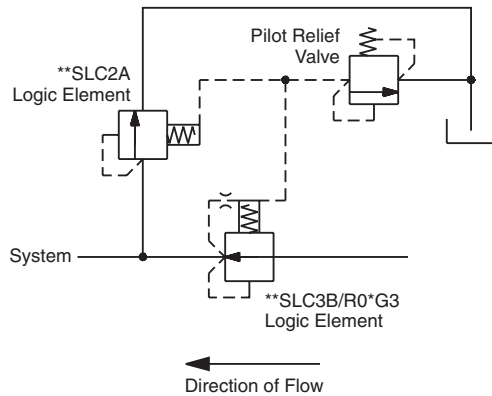

<b>CV</b>
Check Valves
<b>SH</b>
Shuttle Valves
<b>LM</b>
Load/Motor Controls
<b>FC</b>
Flow Controls
<b>PC</b>
Pressure Controls
<b>LE</b>
Logic Elements
<b>DC</b>
Directional Controls
<b>MV</b>
Manual Valves
<b>SV</b>
Solenoid Valves
<b>PV</b>
Proportional Valves
<b>CE</b>
Coils & Electronics
<b>BC</b>
Bodies & Cavities
<b>TD</b>
Technical Data

**Technical Information**

- CV Check Valves
- SH Shuttle Valves
- LM Load/Motor Controls
- FC Flow Controls
- PC Pressure Controls
- LE Logic Elements
- DC Directional Controls
- MV Manual Valves
- SV Solenoid Valves
- PV Proportional Valves
- CE Coils & Electronics
- BC Bodies & Cavities
- TD Technical Data

**General Description**

Poppet Type, Bi-Directional, Normally Closed, Pilot to Close Logic Element. For additional information see Technical Tips on pages LE1-LE6.

**Features**

- Hardened, precision ground parts for durability
- Polyurethane seals only
- No backup rings
- Low leakage design
- All external parts zinc plated

**Performance Curve**

Pressure Drop vs. Flow (Through cartridge only)

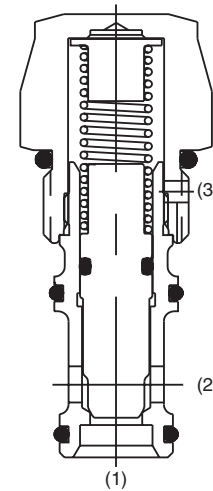
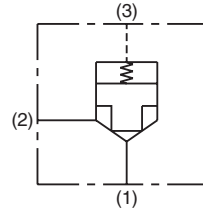
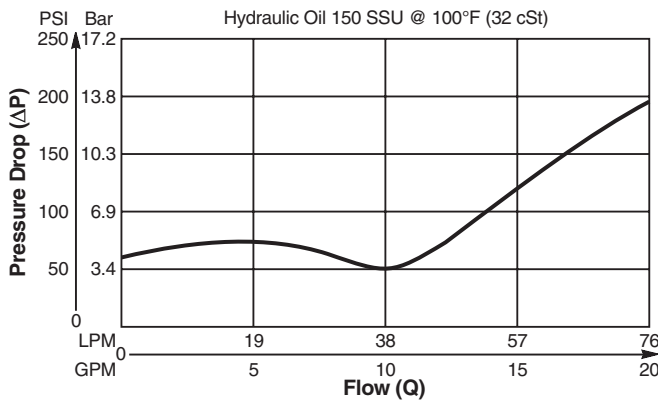

**Dimensions** Millimeters (Inches)

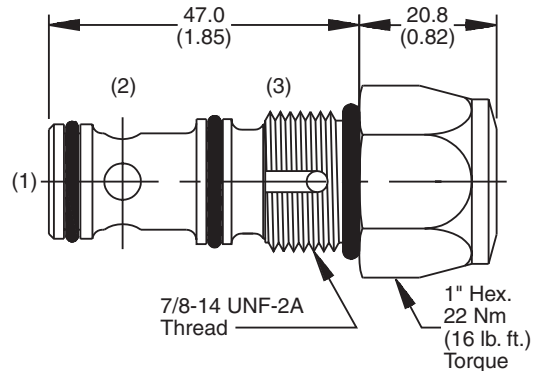

**Specifications**

<b>Rated Flow</b>	57 LPM (15 GPM)
<b>Maximum Inlet Pressure</b>	240 Bar (3500 PSI)
<b>Leakage @ 150 SSU (32 cst)</b>	Port 1 to 2 5 drops/min. (.33 cc/min.) @ 240 Bar (3500 PSI)
<b>Cartridge Material</b>	All parts steel. All operating parts hardened steel.
<b>Operating Temp. Range/Seals</b>	-45°C to +93.3°C (Polyurethane) (-50°F to +200°F)
<b>Fluid Compatibility/ Viscosity</b>	Mineral-based or synthetic with lubricating properties at viscosities of 45 to 2000 SSU (6 to 420 cSt)
<b>Filtration</b>	ISO Code 16/13, SAE Class 4 or better
<b>Approx. Weight</b>	.14 kg (.30 lbs.)
<b>Cavity</b>	C10-3S (See BC Section for more details)
<b>Form Tool</b>	Rougher      NFT10-3SR Finisher      NFT10-3SF

**Ordering Information**

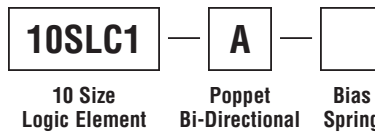

Code	Bias Spring
50	3.5 Bar (50 PSI)
75	5.2 Bar (75 PSI)
100	6.9 Bar (100 PSI)
150	10.3 Bar (150 PSI)

Seal Kit  
WRK-10-3S



**General Description**

Poppet Type, Bi-Directional, Normally Closed, Pilot to Close Logic Element. For additional information see Technical Tips on pages LE1-LE6.

**Features**

- Hardened, precision ground parts for durability
- Polyurethane seals only
- No backup rings
- Low leakage design
- All external parts zinc plated

**Performance Curve**

**Pressure Drop vs. Flow (Through cartridge only)**

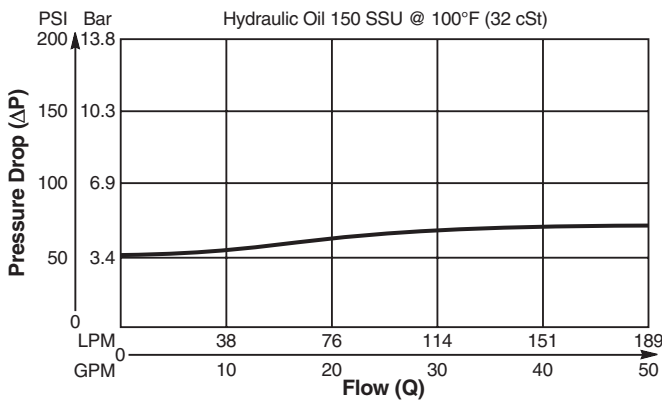

**Specifications**

<b>Rated Flow</b>	189 LPM (50 GPM)
<b>Maximum Inlet Pressure</b>	240 Bar (3500 PSI)
<b>Leakage @ 150 SSU (32 cst)</b>	Port 1 to 2 5 drops/min. (.33 cc/min.) @ 240 Bar (3500 PSI)
<b>Cartridge Material</b>	All parts steel. All operating parts hardened steel.
<b>Operating Temp. Range/Seals</b>	-45°C to +93.3°C (Polyurethane) (-50°F to +200°F)
<b>Fluid Compatibility/ Viscosity</b>	Mineral-based or synthetic with lubricating properties at viscosities of 45 to 2000 SSU (6 to 420 cSt)
<b>Filtration</b>	ISO Code 16/13, SAE Class 4 or better
<b>Approx. Weight</b>	.33 kg (.78 lbs.)
<b>Cavity</b>	C16-3S (See BC Section for more details)
<b>Form Tool</b>	Rougher      NFT16-3SR Finisher      NFT16-3SF

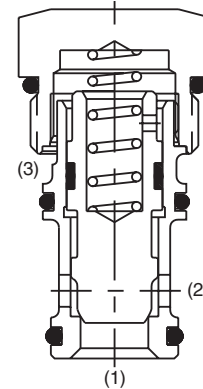
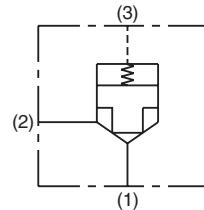

**Dimensions** Millimeters (Inches)

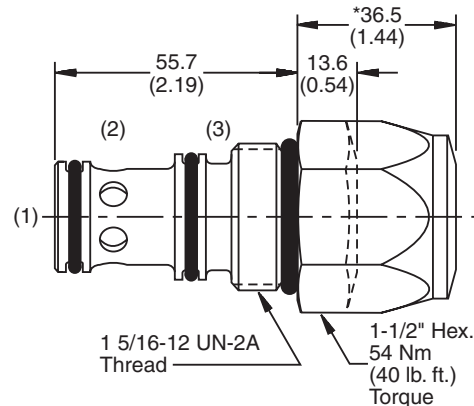

**Ordering Information**

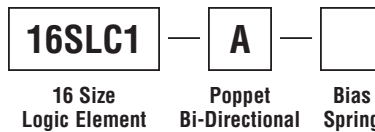

Code	Bias Spring
50	3.5 Bar (50 PSI)
75	5.2 Bar (75 PSI)
*100	6.9 Bar (100 PSI)
*150	10.3 Bar (150 PSI)

\*Indicates larger cap height, see drawing.

**Seal Kit**  
WRK-16-3S

- CV** Check Valves
- SH** Shuttle Valves
- LM** Load/Motor Controls
- FC** Flow Controls
- PC** Pressure Controls
- LE** Logic Elements
- DC** Directional Controls
- MV** Manual Valves
- SV** Solenoid Valves
- PV** Proportional Valves
- CE** Coils & Electronics
- BC** Bodies & Cavities
- TD** Technical Data

**Technical Information**

- CV** Check Valves
- SH** Shuttle Valves
- LM** Load/Motor Controls
- FC** Flow Controls
- PC** Pressure Controls
- LE** Logic Elements
- DC** Directional Controls
- MV** Manual Valves
- SV** Solenoid Valves
- PV** Proportional Valves
- CE** Coils & Electronics
- BC** Bodies & Cavities
- TD** Technical Data

**General Description**

Poppet Type, Bi-Directional, Normally Closed, Pilot to Close Logic Element. For additional information see Technical Tips on pages LE1-LE6.

**Features**

- Hardened, precision ground parts for durability
- Polyurethane seals only
- No backup rings
- Low leakage design
- All external parts zinc plated

**Performance Curve**

**Pressure Drop vs. Flow** (Through cartridge only)

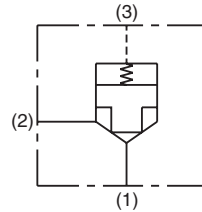
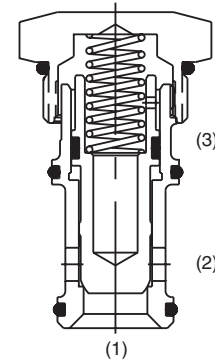
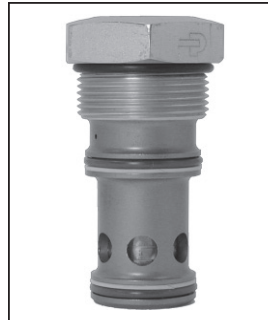
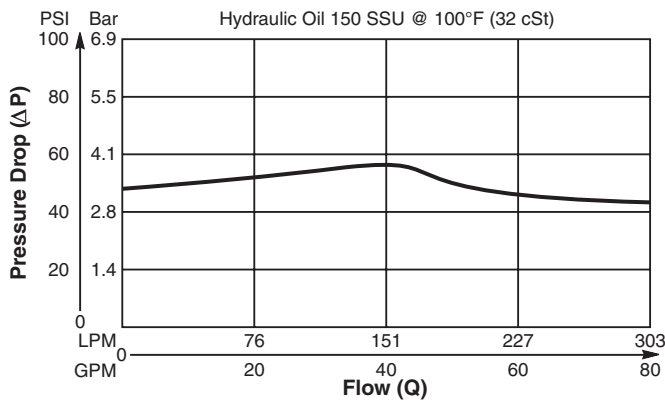

**Dimensions** Millimeters (Inches)

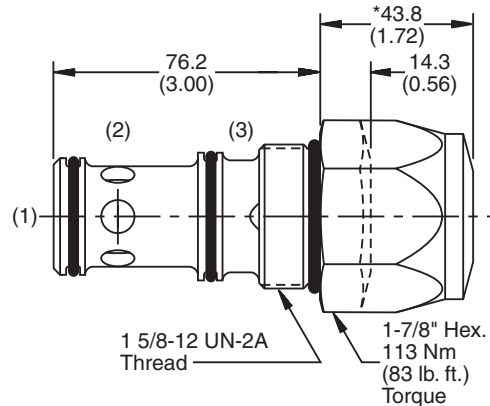

**Specifications**

<b>Rated Flow</b>	303 LPM (80 GPM)
<b>Maximum Inlet Pressure</b>	240 Bar (3500 PSI)
<b>Leakage @ 150 SSU (32 cst)</b>	Port 1 to 2 5 drops/min. (.33 cc/min.) @ 240 Bar (3500 PSI)
<b>Cartridge Material</b>	All parts steel. All operating parts hardened steel.
<b>Operating Temp. Range/Seals</b>	-45°C to +93.3°C (Polyurethane) (-50°F to +200°F)
<b>Fluid Compatibility/Viscosity</b>	Mineral-based or synthetic with lubricating properties at viscosities of 45 to 2000 SSU (6 to 420 cSt)
<b>Filtration</b>	ISO Code 16/13, SAE Class 4 or better
<b>Approx. Weight</b>	.81 kg (1.78 lbs.)
<b>Cavity</b>	C20-3S (See BC Section for more details)
<b>Form Tool</b>	Rougher      NFT20-3SR Finisher      NFT20-3SF

**Ordering Information**

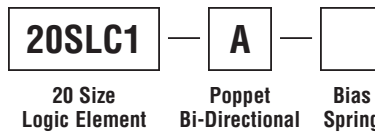

Code	Bias Spring
50	3.5 Bar (50 PSI)
*75	5.2 Bar (75 PSI)
*100	6.9 Bar (100 PSI)
*150	10.3 Bar (150 PSI)

\*Indicates larger cap height, see drawing.

**Seal Kit**  
WRK-20-3S

**General Description**

Poppet Type , Normally Closed, Vent to Open Logic Element. Generation port is from 2 to 3. For additional information see Technical Tips on pages LE1-LE6.

**Features**

- Hardened, precision ground parts for durability
- Polyurethane seals only
- No backup rings
- Low leakage design
- All external parts zinc plated

**Performance Curve**

**Pressure Drop vs. Flow (Through cartridge only)**

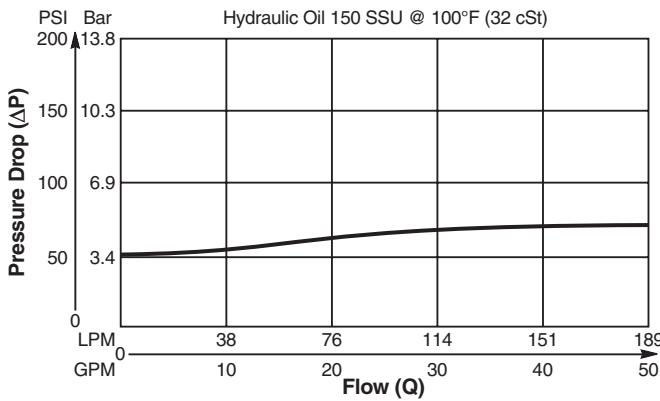

**Specifications**

<b>Rated Flow</b>	189 LPM (50 GPM)
<b>Maximum Inlet Pressure</b>	240 Bar (3500 PSI)
<b>Leakage @ 150 SSU (32 cst)</b>	Port 1 to 2 5 drops/min. (.33 cc/min.) @ 240 Bar (3500 PSI)
<b>Cartridge Material</b>	All parts steel. All operating parts hardened steel.
<b>Operating Temp. Range/Seals</b>	-45°C to +93.3°C (Polyurethane) (-50°F to +200°F)
<b>Fluid Compatibility/ Viscosity</b>	Mineral-based or synthetic with lubricating properties at viscosities of 45 to 2000 SSU (6 to 420 cSt)
<b>Filtration</b>	ISO Code 16/13, SAE Class 4 or better
<b>Approx. Weight</b>	.33 kg (.78 lbs.)
<b>Cavity</b>	C16-3S (See BC Section for more details)
<b>Form Tool</b>	Rougher      NFT16-3SR Finisher      NFT16-3SF

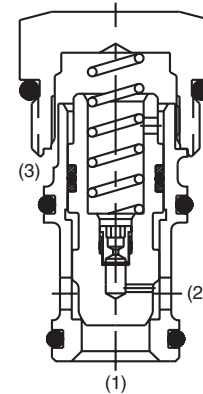
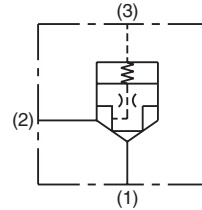

**Dimensions** Millimeters (Inches)

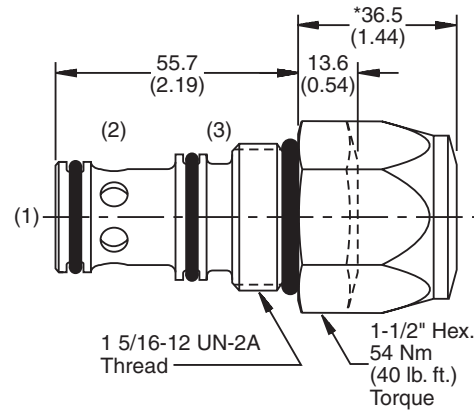

**Ordering Information**

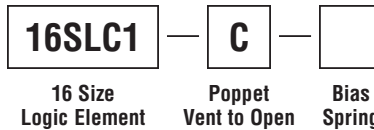

Code	Bias Spring
50	3.5 Bar (50 PSI)
75	5.2 Bar (75 PSI)
*100	6.9 Bar (100 PSI)
*150	10.3 Bar (150 PSI)

\*Indicates larger cap height, see drawing.

**Seal Kit**  
WRK-16-3S

- CV** Check Valves
- SH** Shuttle Valves
- LM** Load/Motor Controls
- FC** Flow Controls
- PC** Pressure Controls
- LE** Logic Elements
- DC** Directional Controls
- MV** Manual Valves
- SV** Solenoid Valves
- PV** Proportional Valves
- CE** Coils & Electronics
- BC** Bodies & Cavities
- TD** Technical Data

**Technical Information**

- CV** Check Valves
- SH** Shuttle Valves
- LM** Load/Motor Controls
- FC** Flow Controls
- PC** Pressure Controls
- LE** Logic Elements
- DC** Directional Controls
- MV** Manual Valves
- SV** Solenoid Valves
- PV** Proportional Valves
- CE** Coils & Electronics
- BC** Bodies & Cavities
- TD** Technical Data

**General Description**

Spool Type, Normally Closed, Pilot to Close Logic Element. For additional information see Technical Tips on pages LE1-LE6.

**Features**

- Hardened, precision ground parts for durability
- Polyurethane seals only
- No backup rings
- All external parts zinc plated

**Performance Curve**

**Pressure Drop vs. Flow** (Through cartridge only)

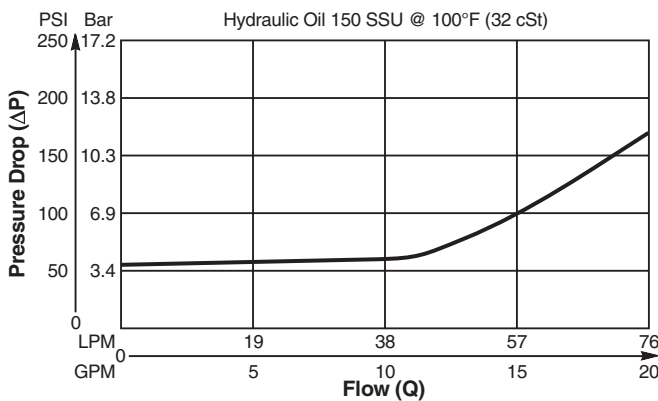

**Specifications**

<b>Rated Flow</b>	57 LPM (15 GPM)
<b>Maximum Inlet Pressure</b>	240 Bar (3500 PSI)
<b>Leakage @ 150 SSU (32 cst)</b>	Port 1 to 2 82 cc/min. (5 in <sup>3</sup> /min.) @ 240 Bar (3500 PSI)
<b>Cartridge Material</b>	All parts steel. All operating parts hardened steel.
<b>Operating Temp. Range/Seals</b>	-45°C to +93.3°C (Polyurethane) (-50°F to +200°F)
<b>Fluid Compatibility/Viscosity</b>	Mineral-based or synthetic with lubricating properties at viscosities of 45 to 2000 SSU (6 to 420 cSt)
<b>Filtration</b>	ISO Code 16/13, SAE Class 4 or better
<b>Approx. Weight</b>	.14 kg (.30 lbs.)
<b>Cavity</b>	C10-3S (See BC Section for more details)
<b>Form Tool</b>	Rougher      NFT10-3SR Finisher      NFT10-3SF

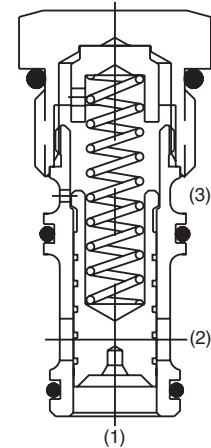
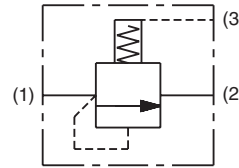
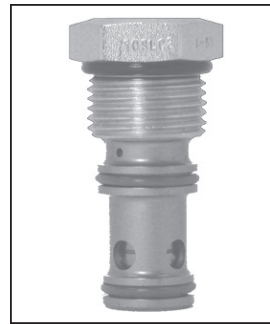

**Dimensions** Millimeters (Inches)

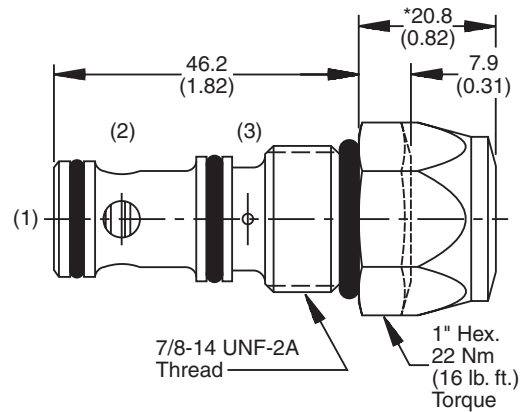

**Ordering Information**

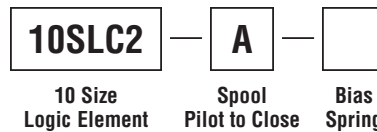

Code	Bias Spring
25	1.7 Bar (25 PSI)
50	3.5 Bar (50 PSI)
75	5.2 Bar (75 PSI)
*100	6.9 Bar (100 PSI)
*150	10.3 Bar (150 PSI)

\*Indicates larger cap height, see drawing.

**Seal Kit**  
WRK-10-3S

**Technical Information**

**General Description**

Spool Type , Normally Closed, Pilot to Close Logic Element. For additional information see Technical Tips on pages LE1-LE6.

**Features**

- Hardened, precision ground parts for durability
- Polyurethane seals only
- No backup rings
- All external parts zinc plated

**Performance Curve**

Pressure Drop vs. Flow (Through cartridge only)

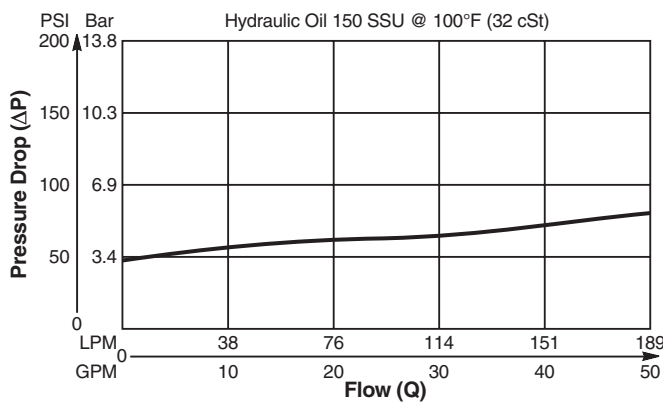

**Specifications**

<b>Rated Flow</b>	189 LPM (50 GPM)
<b>Maximum Inlet Pressure</b>	240 Bar (3500 PSI)
<b>Leakage @ 150 SSU (32 cst)</b>	Port 1 to 2 82 cc/min. (5 in <sup>3</sup> /min.) @ 240 Bar (3500 PSI)
<b>Cartridge Material</b>	All parts steel. All operating parts hardened steel.
<b>Operating Temp. Range/Seals</b>	-45°C to +93.3°C (Polyurethane) (-50°F to +200°F)
<b>Fluid Compatibility/ Viscosity</b>	Mineral-based or synthetic with lubricating properties at viscosities of 45 to 2000 SSU (6 to 420 cSt)
<b>Filtration</b>	ISO Code 16/13, SAE Class 4 or better
<b>Approx. Weight</b>	.33 kg (.78 lbs.)
<b>Cavity</b>	C16-3S (See BC Section for more details)
<b>Form Tool</b>	Rougher      NFT16-3SR Finisher      NFT16-3SF

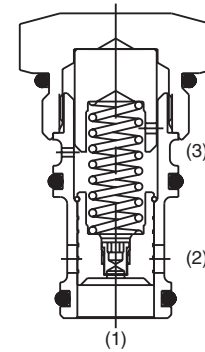
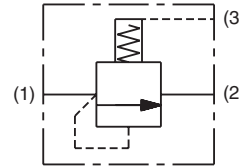
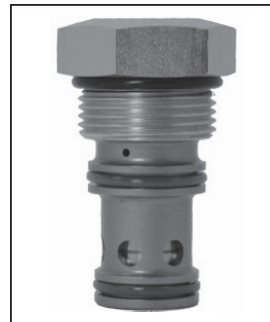

**Dimensions** Millimeters (Inches)

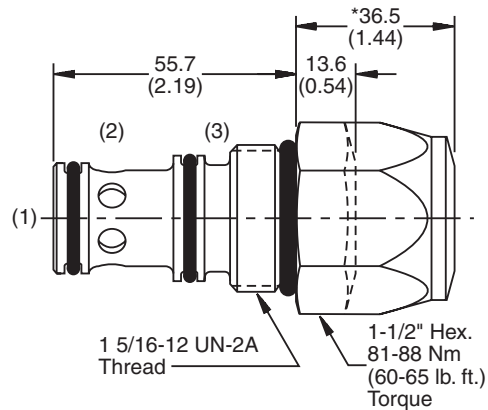

**Ordering Information**

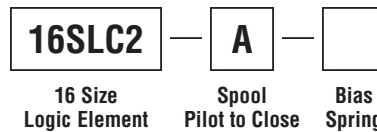

Code	Bias Spring
25	1.7 Bar (25 PSI)
50	3.5 Bar (50 PSI)
75	5.2 Bar (75 PSI)
*100	6.9 Bar (100 PSI)
*150	10.3 Bar (150 PSI)

\*Indicates larger cap height, see drawing.

Seal Kit  
WRK-16-3S

- CV Check Valves
- SH Shuttle Valves
- LM Load/Motor Controls
- FC Flow Controls
- PC Pressure Controls
- LE Logic Elements
- DC Directional Controls
- MV Manual Valves
- SV Solenoid Valves
- PV Proportional Valves
- CE Coils & Electronics
- BC Bodies & Cavities
- TD Technical Data

**Technical Information**

- CV** Check Valves
- SH** Shuttle Valves
- LM** Load/Motor Controls
- FC** Flow Controls
- PC** Pressure Controls
- LE** Logic Elements
- DC** Directional Controls
- MV** Manual Valves
- SV** Solenoid Valves
- PV** Proportional Valves
- CE** Coils & Electronics
- BC** Bodies & Cavities
- TD** Technical Data

**General Description**

Spool Type, Normally Closed, Pilot to Close Logic Element. For additional information see Technical Tips on pages LE1-LE6.

**Features**

- Hardened, precision ground parts for durability
- Polyurethane seals only
- No backup rings
- All external parts zinc plated

**Performance Curve**

Pressure Drop vs. Flow (Through cartridge only)

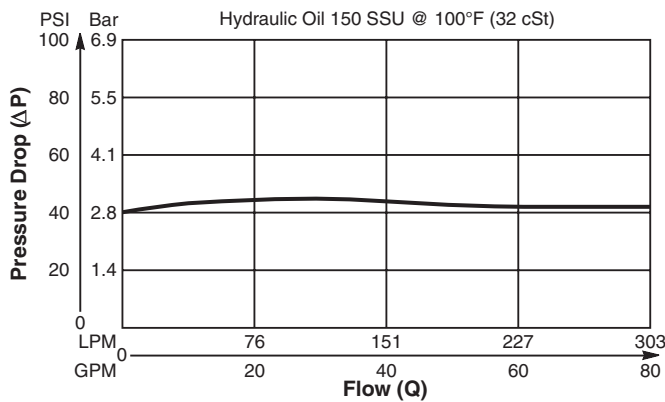

**Specifications**

<b>Rated Flow</b>	303 LPM (80 GPM)
<b>Maximum Inlet Pressure</b>	240 Bar (3500 PSI)
<b>Leakage @ 150 SSU (32 cst)</b>	Port 1 to 2 82 cc/min. (5 in <sup>3</sup> /min.) @ 240 Bar (3500 PSI)
<b>Cartridge Material</b>	All parts steel. All operating parts hardened steel.
<b>Operating Temp. Range/Seals</b>	-45°C to +93.3°C (Polyurethane) (-50°F to +200°F)
<b>Fluid Compatibility/Viscosity</b>	Mineral-based or synthetic with lubricating properties at viscosities of 45 to 2000 SSU (6 to 420 cSt)
<b>Filtration</b>	ISO Code 16/13, SAE Class 4 or better
<b>Approx. Weight</b>	.81 kg (1.78 lbs.)
<b>Cavity</b>	C20-3S (See BC Section for more details)
<b>Form Tool</b>	Rougher      NFT20-3SR Finisher      NFT20-3SF

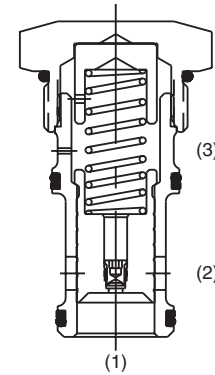
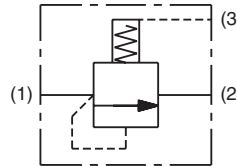
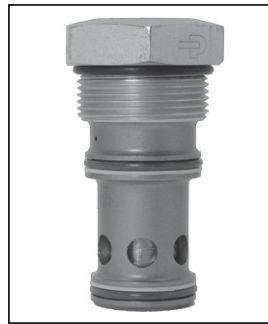

**Dimensions** Millimeters (Inches)

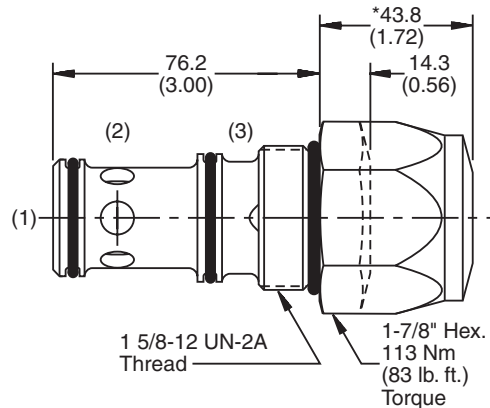

**Ordering Information**

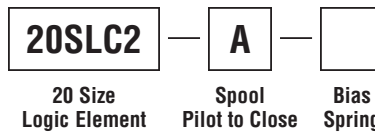

Code	Bias Spring
25	1.7 Bar (25 PSI)
50	3.5 Bar (50 PSI)
*75	5.2 Bar (75 PSI)
*100	6.9 Bar (100 PSI)
*150	10.3 Bar (150 PSI)

\*Indicates larger cap height, see drawing.

Seal Kit  
WRK-20-3S

**General Description**

Spool Type , Normally Closed, Pilot to Close Logic Element. For additional information see Technical Tips on pages LE1-LE6.

**Features**

- High flow capacity
- Used as high flow switching or metering element
- Can be used as bleed off style pressure compensated flow regulator when used with restrictor
- More stable than poppet type
- Various switching pressures available
- 1:1 pilot pressure ratio
- Hardened working parts for maximum durability
- All external parts zinc plated

**Performance Curve (Through cartridge only)**

**Vented Open Pressure Drop vs. Flow 1 to 2**

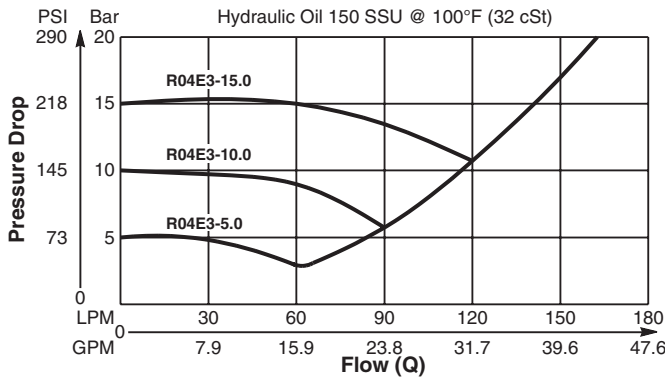

**Specifications**

<b>Rated Flow</b>	170 LPM (45 GPM)
<b>Nominal Flow @ 7 Bar (100 PSI)</b>	100 LPM (26 GPM)
<b>Maximum Inlet Pressure</b>	420 Bar (6000 PSI)
<b>Leakage @ 150 SSU (32 cst)</b>	50 ml/min. @ 100 Bar (1450 PSI)
<b>Switching Press.</b>	See ordering information
<b>Cartridge Material</b>	All parts steel. All operating parts hardened steel.
<b>Operating Temp. Range/Seals</b>	-40°C to +93.3°C (Nitrile) (-40°F to +200°F) -31.7°C to +121.1°C (Fluorocarbon) (-25°F to +250°F)
<b>Fluid Compatibility/Viscosity</b>	Mineral-based or synthetic with lubricating properties at viscosities of 45 to 2000 SSU (6 to 420 cSt)
<b>Filtration</b>	ISO Code 16/13, SAE Class 4 or better
<b>Approx. Weight</b>	.14 kg (.31 lbs.)
<b>Cavity</b>	C10-3S (See BC Section for more details)
<b>Form Tool</b>	Rougher NFT10-3SR Finisher NFT10-3SF

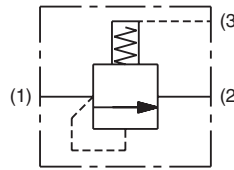
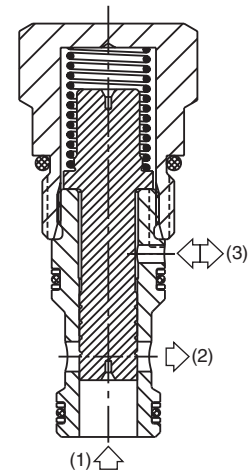

**Dimensions** Millimeters (Inches)

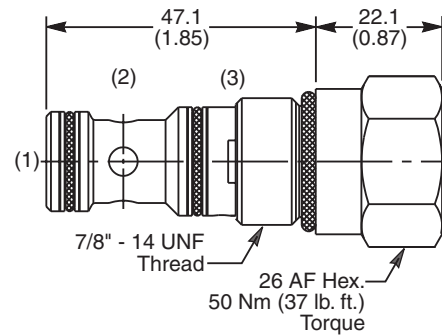

**Ordering Information**

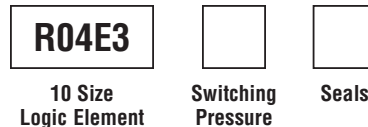

Code	Switching Pressure Non Adjustable Preset
1.0	1.0 Bar (14.5 PSI)
5.0	5.0 Bar (73 PSI) Std.
10.0	10.0 Bar (145 PSI)
15.0	15.0 Bar (218 PSI)
20.0	20.0 Bar (290 PSI)

Code	Seals / Kit. No.
N	Nitrile, Buna-N (Std.) / (SK30504N-1)
V	Fluorocarbon / (SK30504V-1)

*If no switching pressure is specified, valve will be supplied as R04E3-5.0N*

**CV**

Check Valves

**SH**

Shuttle Valves

**LM**

Load/Motor Controls

**FC**

Flow Controls

**PC**

Pressure Controls

**LE**

Logic Elements

**DC**

Directional Controls

**MV**

Manual Valves

**SV**

Solenoid Valves

**PV**

Proportional Valves

**CE**

Coils & Electronics

**BC**

Bodies & Cavities

**TD**

Technical Data

**Technical Information**

- CV** Check Valves
- SH** Shuttle Valves
- LM** Load/Motor Controls
- FC** Flow Controls
- PC** Pressure Controls
- LE** Logic Elements
- DC** Directional Controls
- MV** Manual Valves
- SV** Solenoid Valves
- PV** Proportional Valves
- CE** Coils & Electronics
- BC** Bodies & Cavities
- TD** Technical Data

**General Description**

Spool Type , Normally Closed, Pilot to Close Logic Element. For additional information see Technical Tips on pages LE1-LE6.

**Features**

- High flow capacity
- Used as high flow switching or metering element
- Can be used as bleed off style pressure compensated flow regulator when used with restrictor
- More stable than poppet type
- Various switching pressures available
- 1:1 pilot pressure ratio
- Hardened working parts for maximum durability
- All external parts zinc plated

**Performance Curve (Through cartridge only)**

**Vented Open Pressure Drop vs. Flow 1 to 2**

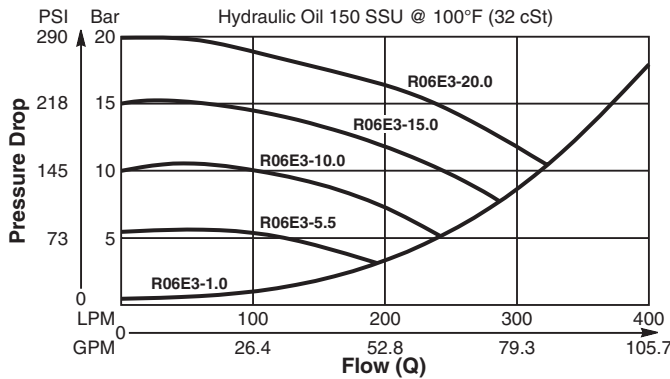

**Specifications**

<b>Rated Flow</b>	400 LPM (106 GPM)
<b>Nominal Flow @ 7 Bar (100 PSI)</b>	270 LPM (71 GPM)
<b>Maximum Inlet Pressure</b>	420 Bar (6000 PSI)
<b>Leakage @ 150 SSU (32 cst)</b>	90 ml/min. @ 100 Bar (1450 PSI)
<b>Switching Press.</b>	See ordering information
<b>Cartridge Material</b>	All parts steel. All operating parts hardened steel.
<b>Operating Temp. Range/Seals</b>	-40°C to +93.3°C (Nitrile) (-40°F to +200°F) -31.7°C to +121.1°C (Fluorocarbon) (-25°F to +250°F)
<b>Fluid Compatibility/ Viscosity</b>	Mineral-based or synthetic with lubricating properties at viscosities of 45 to 2000 SSU (6 to 420 cSt)
<b>Filtration</b>	ISO Code 16/13, SAE Class 4 or better
<b>Approx. Weight</b>	.38 kg (.84 lbs.)
<b>Cavity</b>	C16-3S (See BC Section for more details)
<b>Form Tool</b>	Rougher NFT16-3SR Finisher NFT16-3SF

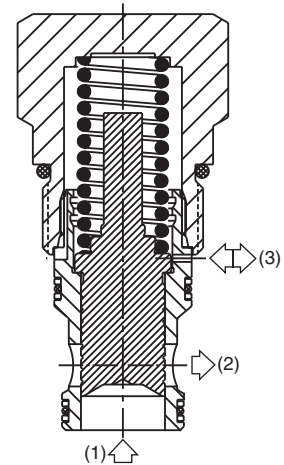
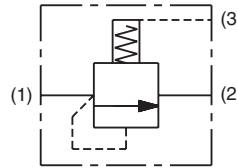
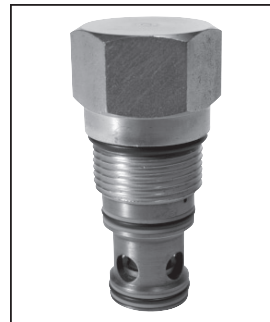

**Dimensions** Millimeters (Inches)

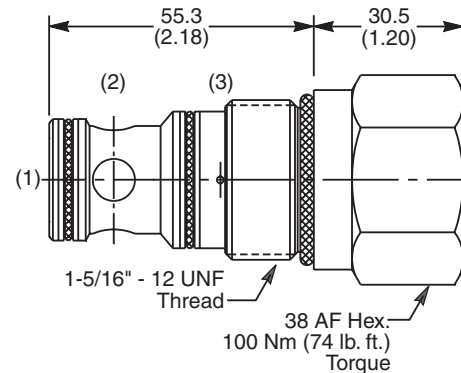

**Ordering Information**

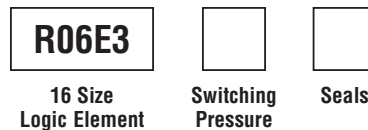

Code	Switching Pressure Non Adjustable Preset
1.0	1.0 Bar (14.5 PSI)
5.5	5.5 Bar (80 PSI) Std.
10.0	10.0 Bar (145 PSI)
15.0	15.0 Bar (218 PSI)
20.0	20.0 Bar (290 PSI)

Code	Seals / Kit. No.
N	Nitrile, Buna-N (Std.) / (SK30508N-1)
V	Fluorocarbon / (SK30508V-1)

*If no switching pressure is specified, valve will be supplied as R06E3-5.5N*



**General Description**

Spool Type , Normally Closed, Pilot to Close Logic Element. For additional information see Technical Tips on pages LE1-LE6.

**Features**

- High flow capacity
- Can be used as high flow switching or metering element
- Can be used as bleed off style pressure compensated flow regulator when used with restrictor
- Various switching pressures available
- 1:1 pilot pressure ratio
- Hardened working parts for maximum durability
- All external parts zinc plated

**Performance Curve (Through cartridge only)  
Vented Open Pressure Drop vs. Flow 1 to 2**

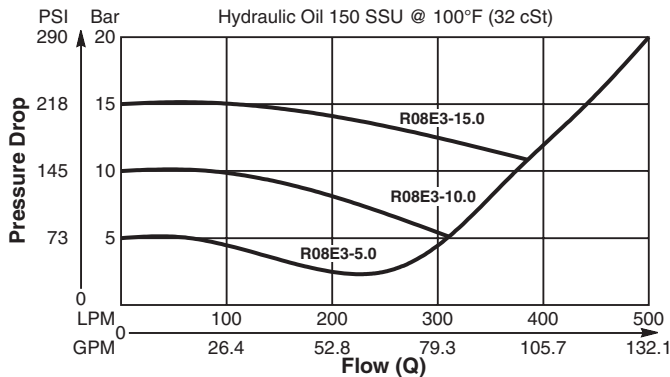

**Specifications**

<b>Rated Flow</b>	500 LPM (132 GPM)
<b>Nominal Flow @ 7 Bar (100 PSI)</b>	340 LPM (90 GPM)
<b>Maximum Inlet Pressure</b>	420 Bar (6000 PSI)
<b>Leakage @ 150 SSU (32 cst)</b>	90 ml/min. @ 100 Bar (1450 PSI)
<b>Switching Press.</b>	See ordering information
<b>Cartridge Material</b>	All parts steel. All operating parts hardened steel.
<b>Operating Temp. Range/Seals</b>	-40°C to +93.3°C (Nitrile) (-40°F to +200°F) -31.7°C to +121.1°C (Fluorocarbon) (-25°F to +250°F)
<b>Fluid Compatibility/Viscosity</b>	Mineral-based or synthetic with lubricating properties at viscosities of 45 to 2000 SSU (6 to 420 cSt)
<b>Filtration</b>	ISO Code 16/13, SAE Class 4 or better
<b>Approx. Weight</b>	.69 kg (1.52 lbs.)
<b>Cavity</b>	C20-3S (See BC Section for more details)
<b>Form Tool</b>	Rougher NFT20-3SR Finisher NFT20-3SF

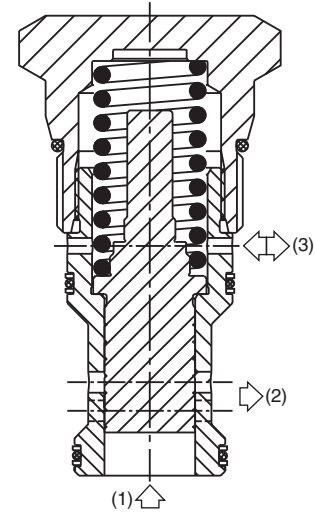
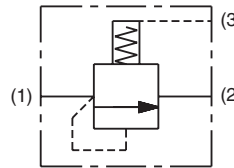
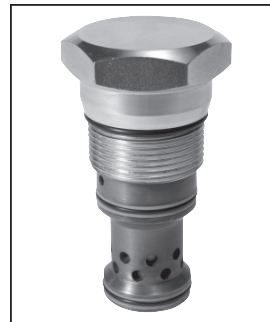

**Dimensions** Millimeters (Inches)

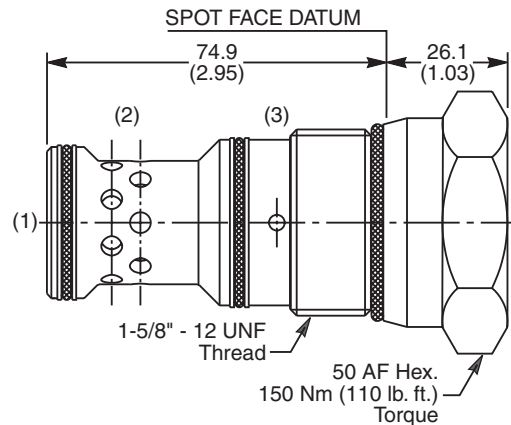

**Ordering Information**

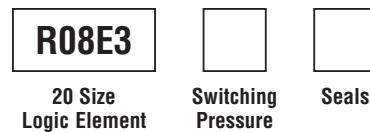

Code	Switching Pressure Non Adjustable Preset
5.5	5.5 Bar (80 PSI) Std.
10.0	10.0 Bar (145 PSI)
15.0	15.0 Bar (218 PSI)
20.0	20.0 Bar (290 PSI)

Code	Seals / Kit. No.
N	Nitrile, Buna-N (Std.) / (SK30512N-1)
V	Fluorocarbon / (SK30512V-1)

*If no switching pressure is specified, valve will be supplied as R06E3-5.5N*

- CV** Check Valves
- SH** Shuttle Valves
- LM** Load/Motor Controls
- FC** Flow Controls
- PC** Pressure Controls
- LE** Logic Elements
- DC** Directional Controls
- MV** Manual Valves
- SV** Solenoid Valves
- PV** Proportional Valves
- CE** Coils & Electronics
- BC** Bodies & Cavities
- TD** Technical Data

**Technical Information**

- CV** Check Valves
- SH** Shuttle Valves
- LM** Load/Motor Controls
- FC** Flow Controls
- PC** Pressure Controls
- LE** Logic Elements
- DC** Directional Controls
- MV** Manual Valves
- SV** Solenoid Valves
- PV** Proportional Valves
- CE** Coils & Electronics
- BC** Bodies & Cavities
- TD** Technical Data

**General Description**

Spool Type, Normally Closed, Vent to Open Logic Element. For additional information see Technical Tips on pages LE1-LE6.

**Features**

- Hardened, precision ground parts for durability
- Polyurethane seals only
- No backup rings
- All external parts zinc plated

**Performance Curve**

**Pressure Drop vs. Flow** (Through cartridge only)

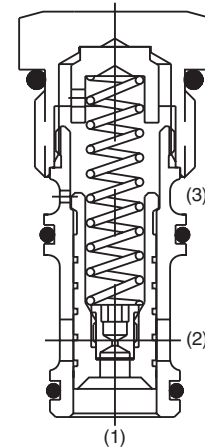
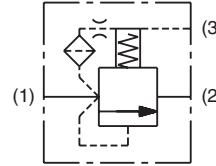
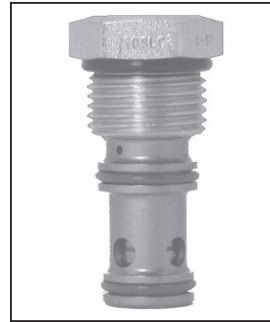
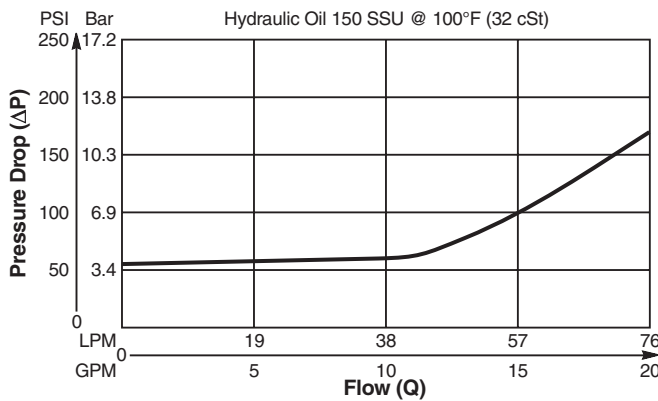

**Dimensions** Millimeters (Inches)

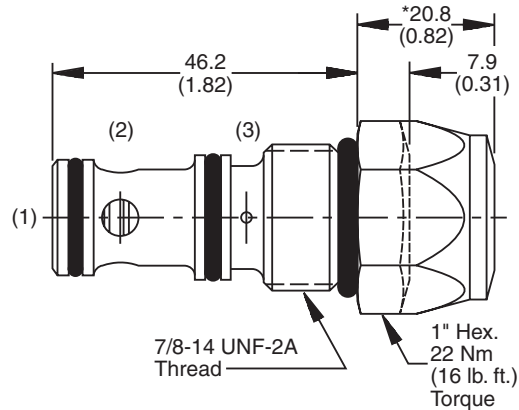

**Specifications**

<b>Rated Flow</b>	57 LPM (15 GPM)
<b>Maximum Inlet Pressure</b>	240 Bar (3500 PSI)
<b>Leakage @ 150 SSu (32 cst)</b>	Port 1 to 2 82 cc/min. (5 in <sup>3</sup> /min.) @ 240 Bar (3500 PSI)
<b>Cartridge Material</b>	All parts steel. All operating parts hardened steel.
<b>Operating Temp. Range/Seals</b>	-45°C to +93.3°C (Polyurethane) (-50°F to +200°F)
<b>Fluid Compatibility/Viscosity</b>	Mineral-based or synthetic with lubricating properties at viscosities of 45 to 2000 SSU (6 to 420 cSt)
<b>Filtration</b>	ISO Code 16/13, SAE Class 4 or better
<b>Approx. Weight</b>	.14 kg (.30 lbs.)
<b>Cavity</b>	C10-3S (See BC Section for more details)
<b>Form Tool</b>	Rougher      NFT10-3SR Finisher      NFT10-3SF

**Ordering Information**

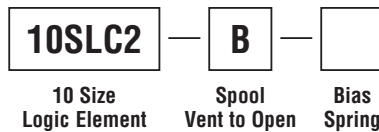

Code	Bias Spring
25	1.7 Bar (25 PSI)
50	3.5 Bar (50 PSI)
75	5.2 Bar (75 PSI)
*100	6.9 Bar (100 PSI)
*150	10.3 Bar (150 PSI)

\*Indicates larger cap height, see drawing.

**Seal Kit**  
WRK-10-3S

**General Description**

Spool Type , Normally Closed, Vent to Open Logic Element. For additional information see Technical Tips on pages LE1-LE6.

**Features**

- Hardened, precision ground parts for durability
- Polyurethane seals only
- No backup rings
- All external parts zinc plated

**Performance Curve**

**Pressure Drop vs. Flow (Through cartridge only)**

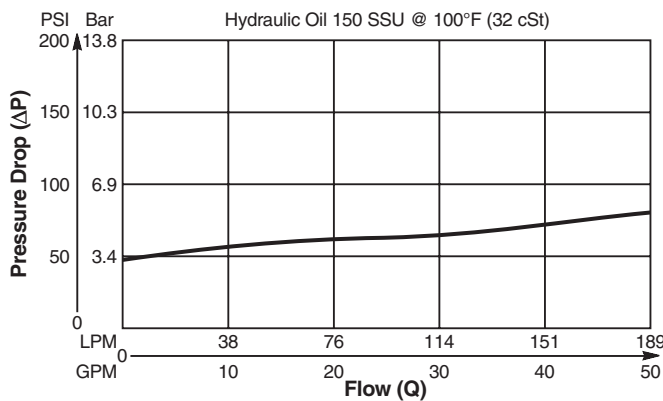

**Specifications**

<b>Rated Flow</b>	189 LPM (50 GPM)
<b>Maximum Inlet Pressure</b>	240 Bar (3500 PSI)
<b>Leakage @ 150 SSU (32 cst)</b>	Port 1 to 2 82 cc/min. (5 in <sup>3</sup> /min.) @ 240 Bar (3500 PSI)
<b>Cartridge Material</b>	All parts steel. All operating parts hardened steel.
<b>Operating Temp. Range/Seals</b>	-45°C to +93.3°C (Polyurethane) (-50°F to +200°F)
<b>Fluid Compatibility/ Viscosity</b>	Mineral-based or synthetic with lubricating properties at viscosities of 45 to 2000 SSU (6 to 420 cSt)
<b>Filtration</b>	ISO Code 16/13, SAE Class 4 or better
<b>Approx. Weight</b>	.33 kg (.78 lbs.)
<b>Cavity</b>	C16-3S (See BC Section for more details)
<b>Form Tool</b>	Rougher      NFT16-3SR Finisher      NFT16-3SF

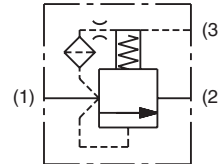
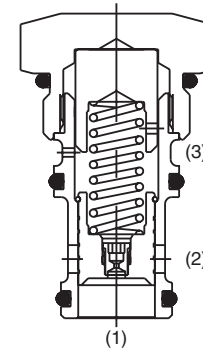

**Dimensions** Millimeters (Inches)

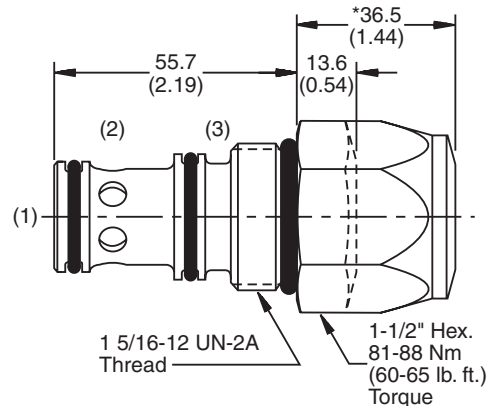

**Ordering Information**

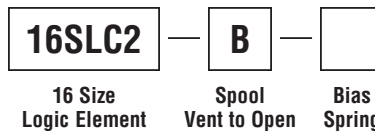

Code	Bias Spring
25	1.7 Bar (25 PSI)
50	3.5 Bar (50 PSI)
75	5.2 Bar (75 PSI)
*100	6.9 Bar (100 PSI)
*150	10.3 Bar (150 PSI)

\*Indicates larger cap height, see drawing.

**Seal Kit**  
WRK-16-3S

**CV**

Check Valves

**SH**

Shuttle Valves

**LM**

Load/Motor Controls

**FC**

Flow Controls

**PC**

Pressure Controls

**LE**

Logic Elements

**DC**

Directional Controls

**MV**

Manual Valves

**SV**

Solenoid Valves

**PV**

Proportional Valves

**CE**

Coils & Electronics

**BC**

Bodies & Cavities

**TD**

Technical Data

**Technical Information**

**CV**

Check Valves

**SH**

Shuttle Valves

**LM**  
Load/Motor Controls

**FC**

Flow Controls

**PC**

Pressure Controls

**L**

Logic Elements

**DC**

Directional Controls

**MV**

Manual Valves

**SV**

Solenoid Valves

**PV**

Proportional Valves

**CE**

Coils & Electronics

**BC**

Bodies & Cavities

**TD**

Technical Data

**General Description**

Spool Type, Normally Closed, Vent to Open Logic Element. For additional information see Technical Tips on pages LE1-LE6.

**Features**

- Hardened, precision ground parts for durability
- Polyurethane seals only
- No backup rings
- All external parts zinc plated

**Performance Curve**

Pressure Drop vs. Flow (Through cartridge only)

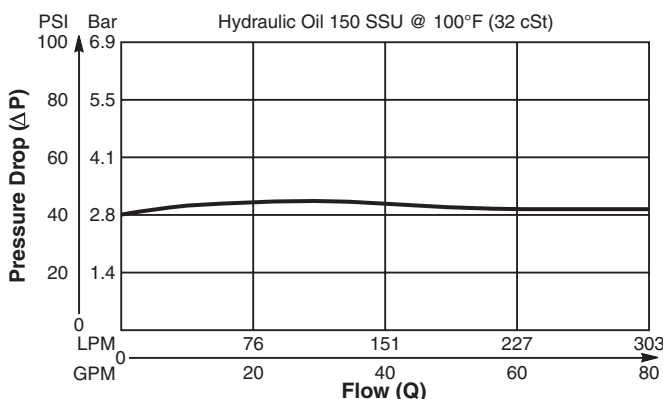

**Specifications**

<b>Rated Flow</b>	303 LPM (80 GPM)
<b>Maximum Inlet Pressure</b>	240 Bar (3500 PSI)
<b>Leakage @ 150 SSU (32 cst)</b>	Port 1 to 2 82 cc/min. (5 in <sup>3</sup> /min.) @ 240 Bar (3500 PSI)
<b>Cartridge Material</b>	All parts steel. All operating parts hardened steel.
<b>Operating Temp. Range/Seals</b>	-45°C to +93.3°C (Polyurethane) (-50°F to +200°F)
<b>Fluid Compatibility/Viscosity</b>	Mineral-based or synthetic with lubricating properties at viscosities of 45 to 2000 SSU (6 to 420 cSt)
<b>Filtration</b>	ISO Code 16/13, SAE Class 4 or better
<b>Approx. Weight</b>	.81 kg (1.78 lbs.)
<b>Cavity</b>	C20-3S (See BC Section for more details)
<b>Form Tool</b>	Rougher      NFT20-3SR Finisher      NFT20-3SF

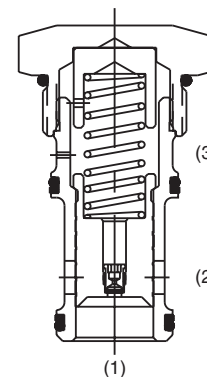
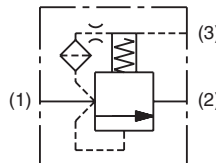

**Dimensions** Millimeters (Inches)

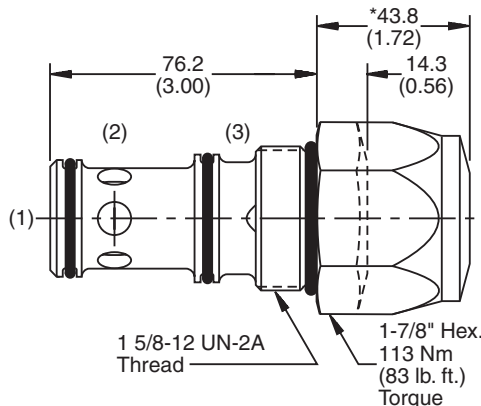

**Ordering Information**

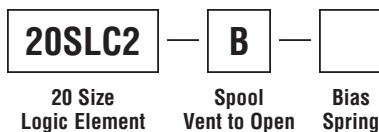

Code	Bias Spring
25	1.7 Bar (25 PSI)
50	3.5 Bar (50 PSI)
*75	5.2 Bar (75 PSI)
*100	6.9 Bar (100 PSI)
*150	10.3 Bar (150 PSI)

\*Indicates larger cap height, see drawing.

**Seal Kit**  
WRK-20-3S

**General Description**

Spool Type , Normally Closed, Vent to Open Logic Element. For additional information see Technical Tips on pages LE1-LE6.

**Features**

- High flow capacity
- Used as high flow switching or metering element
- Can be used as main stage for a pilot operated relief or sequence valve
- Integral 250 micron pilot flow filter
- Various switching pressures available
- 1:1 pilot pressure ratio
- Hardened working parts for maximum durability
- All external parts zinc plated

**Performance Curve (Through cartridge only)**

**Vented Open Pressure Drop vs. Flow 1 to 2**

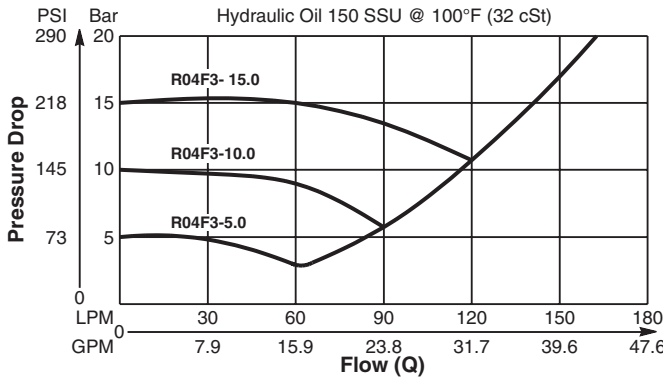

**Specifications**

<b>Rated Flow</b>	170 LPM (45 GPM)
<b>Nominal Flow @ 7 Bar (100 PSI)</b>	100 LPM (26 GPM)
<b>Maximum Inlet Pressure</b>	420 Bar (6000 PSI)
<b>Leakage @ 150 SSU (32 cst)</b>	50 ml/min. @ 100 Bar (1450 PSI)
<b>Switching Press.</b>	See ordering information
<b>Cartridge Material</b>	All parts steel. All operating parts hardened steel.
<b>Operating Temp. Range/Seals</b>	-40°C to +93.3°C (Nitrile) (-40°F to +200°F) -31.7°C to +121.1°C (Fluorocarbon) (-25°F to +250°F)
<b>Fluid Compatibility/Viscosity</b>	Mineral-based or synthetic with lubricating properties at viscosities of 45 to 2000 SSU (6 to 420 cSt)
<b>Filtration</b>	ISO Code 16/13, SAE Class 4 or better
<b>Approx. Weight</b>	.13 kg (.29 lbs.)
<b>Cavity</b>	C10-3S (See BC Section for more details)
<b>Form Tool</b>	Rougher NFT10-3SR Finisher NFT10-3SF

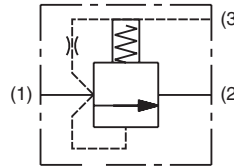
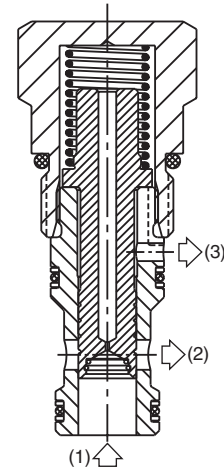

**Dimensions** Millimeters (Inches)

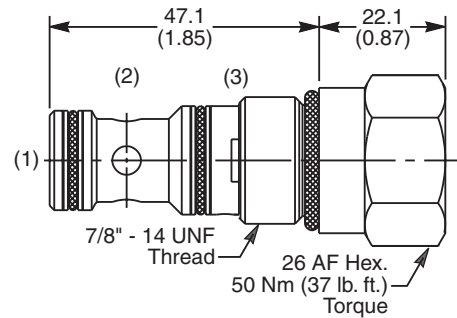

**Ordering Information**

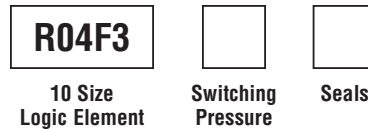

Code	Switching Pressure Non Adjustable Preset
1.0	1.0 Bar (14.5 PSI)
5.0	5.0 Bar (73 PSI) Std.
10.0	10.0 Bar (145 PSI)
15.0	15.0 Bar (218 PSI)
20.0	20.0 Bar (290 PSI)

Code	Seals / Kit. No.
N	Nitrile, Buna-N (Std.) / (SK30504N-1)
V	Fluorocarbon / (SK30504V-1)

*If no switching pressure is specified, valve will be supplied as R04F3-5.0N*

- CV** Check Valves
- SH** Shuttle Valves
- LM** Load/Motor Controls
- FC** Flow Controls
- PC** Pressure Controls
- LE** Logic Elements
- DC** Directional Controls
- MV** Manual Valves
- SV** Solenoid Valves
- PV** Proportional Valves
- CE** Coils & Electronics
- BC** Bodies & Cavities
- TD** Technical Data

**Technical Information**

- CV** Check Valves
- SH** Shuttle Valves
- LM** Load/Motor Controls
- FC** Flow Controls
- PC** Pressure Controls
- LE** Logic Elements
- DC** Directional Controls
- MV** Manual Valves
- SV** Solenoid Valves
- PV** Proportional Valves
- CE** Coils & Electronics
- BC** Bodies & Cavities
- TD** Technical Data

**General Description**

Spool Type , Normally Closed, Vent to Open Logic Element. For additional information see Technical Tips on pages LE1-LE6.

**Features**

- High flow capacity
- Used as high flow switching or metering element
- Can be used as main stage for a pilot operated relief or sequence valve
- Integral 250 micron pilot flow filter
- Various switching pressures available
- 1:1 pilot pressure ratio
- Hardened working parts for maximum durability
- All external parts zinc plated

**Performance Curve (Through cartridge only)**  
**Vented Open Pressure Drop vs. Flow 1 to 2**

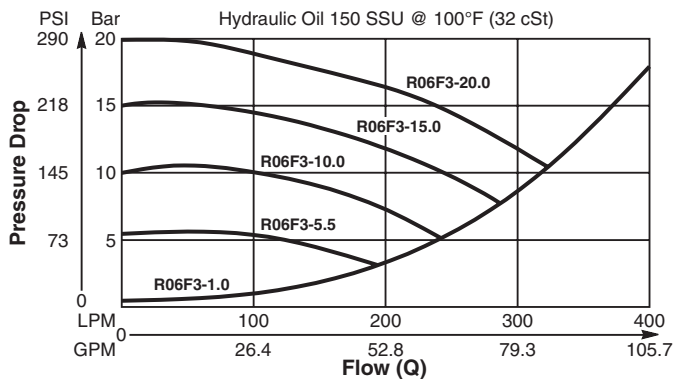

**Specifications**

<b>Rated Flow</b>	400 LPM (106 GPM)
<b>Nominal Flow @ 7 Bar (100 PSI)</b>	270 LPM (71 GPM)
<b>Maximum Inlet Pressure</b>	420 Bar (6000 PSI)
<b>Leakage @ 150 SSU (32 cst)</b>	90 ml/min. @ 100 Bar (1450 PSI)
<b>Switching Press.</b>	See ordering information
<b>Cartridge Material</b>	All parts steel. All operating parts hardened steel.
<b>Operating Temp. Range/Seals</b>	-40°C to +93.3°C (Nitrile) (-40°F to +200°F) -31.7°C to +121.1°C (Fluorocarbon) (-25°F to +250°F)
<b>Fluid Compatibility/Viscosity</b>	Mineral-based or synthetic with lubricating properties at viscosities of 45 to 2000 SSU (6 to 420 cSt)
<b>Filtration</b>	ISO Code 16/13, SAE Class 4 or better
<b>Approx. Weight</b>	.38 kg (.84 lbs.)
<b>Cavity</b>	C16-3S (See BC Section for more details)
<b>Form Tool</b>	Rougher NFT16-3SR Finisher NFT16-3SF

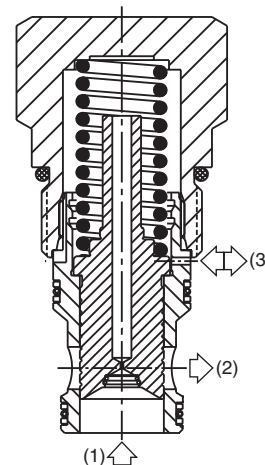
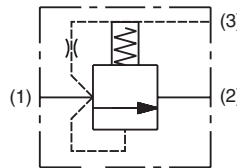
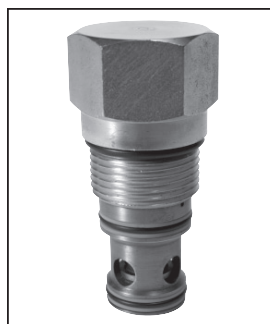

**Dimensions** Millimeters (Inches)

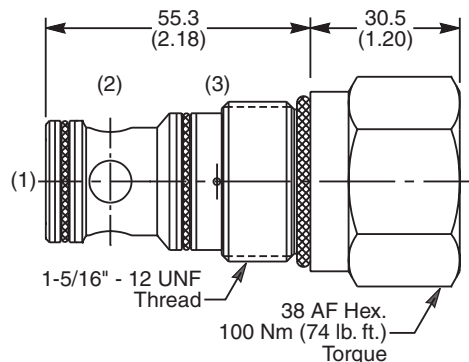

**Ordering Information**

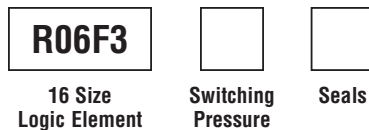

Code	Switching Pressure Non Adjustable Preset
1.0	1.0 Bar (14.5 PSI)
5.5	5.5 Bar (80 PSI) Std.
10.0	10.0 Bar (145 PSI)
15.0	15.0 Bar (218 PSI)
20.0	20.0 Bar (290 PSI)

Code	Seals / Kit. No.
N	Nitrile, Buna-N (Std.) / (SK30508N-1)
V	Fluorocarbon / (SK30508V-1)

*If no switching pressure is specified, valve will be supplied as R06F3-5.5N*

**General Description**

Spool Type , Normally Closed, Vent to Open Logic Element. For additional information see Technical Tips on pages LE1-LE6.

**Features**

- High flow capacity
- Can be used as high flow switching or metering element
- Can be used as main stage for a pilot operated relief or sequence valve
- Integral 250 micron pilot flow filter
- Various switching pressures available
- 1:1 pilot pressure ratio
- Hardened working parts for maximum durability
- All external parts zinc plated

**Performance Curve (Through cartridge only)  
Vented Open Pressure Drop vs. Flow 1 to 2**

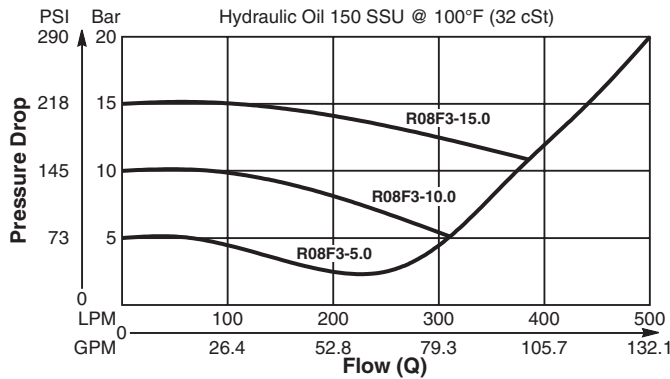

**Specifications**

<b>Rated Flow</b>	500 LPM (132 GPM)
<b>Nominal Flow @ 7 Bar (100 PSI)</b>	340 LPM (90 GPM)
<b>Maximum Inlet Pressure</b>	420 Bar (6000 PSI)
<b>Leakage @ 150 SSU (32 cst)</b>	90 ml/min. @ 100 Bar (1450 PSI)
<b>Switching Press.</b>	See ordering information
<b>Cartridge Material</b>	All parts steel. All operating parts hardened steel.
<b>Operating Temp. Range/Seals</b>	-40°C to +93.3°C (Nitrile) (-40°F to +200°F) -31.7°C to +121.1°C (Fluorocarbon) (-25°F to +250°F)
<b>Fluid Compatibility/Viscosity</b>	Mineral-based or synthetic with lubricating properties at viscosities of 45 to 2000 SSU (6 to 420 cSt)
<b>Filtration</b>	ISO Code 16/13, SAE Class 4 or better
<b>Approx. Weight</b>	.69 kg (1.52 lbs.)
<b>Cavity</b>	C20-3S (See BC Section for more details)
<b>Form Tool</b>	Rougher NFT20-3SR Finisher NFT20-3SF

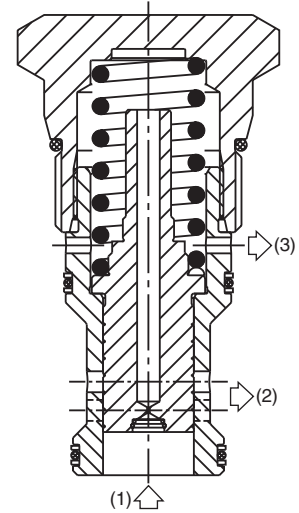
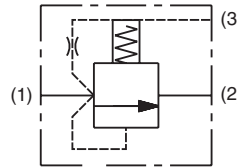
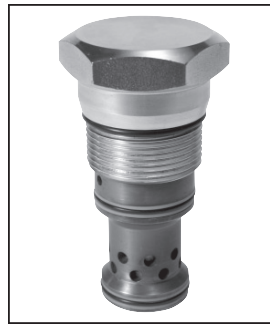

**Dimensions** Millimeters (Inches)

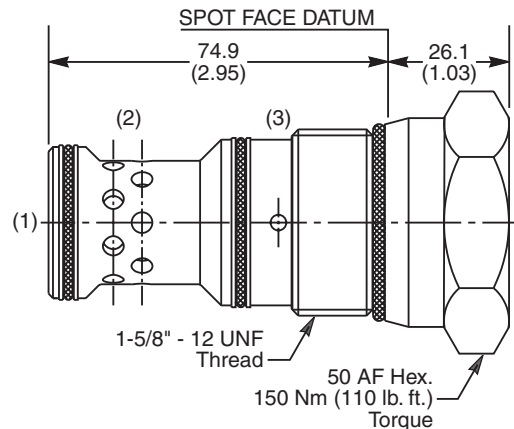

**Ordering Information**

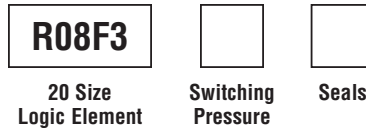

Code	Switching Pressure Non Adjustable Preset
5.5	5.5 Bar (80 PSI) Std.
10.0	10.0 Bar (145 PSI)
15.0	15.0 Bar (218 PSI)
20.0	20.0 Bar (290 PSI)

Code	Seals / Kit. No.
N	Nitrile, Buna-N (Std.) / (SK30512N-1)
V	Fluorocarbon / (SK30512V-1)

*If no switching pressure is specified, valve will be supplied as R08E3-5.5N*

**CV**

Check Valves

**SH**

Shuttle Valves

**LM**

Load/Motor Controls

**FC**

Flow Controls

**PC**

Pressure Controls

**LE**

Logic Elements

**DC**

Directional Controls

**MV**

Manual Valves

**SV**

Solenoid Valves

**PV**

Proportional Valves

**CE**

Coils & Electronics

**BC**

Bodies & Cavities

**TD**

Technical Data

**Technical Information**

- CV** Check Valves
- SH** Shuttle Valves
- LM** Load/Motor Controls
- FC** Flow Controls
- PC** Pressure Controls
- LE** Logic Elements
- DC** Directional Controls
- MV** Manual Valves
- SV** Solenoid Valves
- PV** Proportional Valves
- CE** Coils & Electronics
- BC** Bodies & Cavities
- TD** Technical Data

**General Description**

Spool Type, Normally Open, Logic Element. This type is ideal for flow control functions. For additional information see Technical Tips on pages LE1-LE6.

**Features**

- Hardened, precision ground parts for durability
- Polyurethane seals only
- No backup rings
- All external parts zinc plated

**Performance Curve**

Pressure Drop vs. Flow (Through cartridge only)

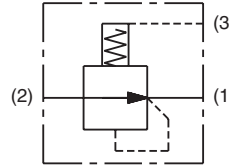
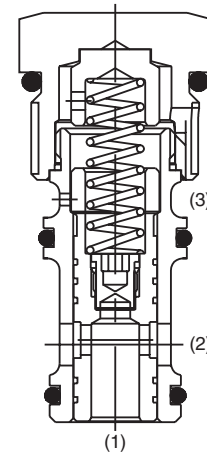
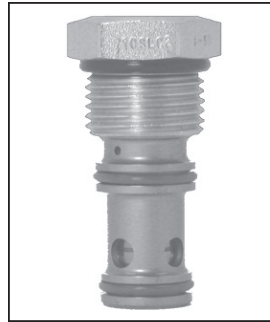
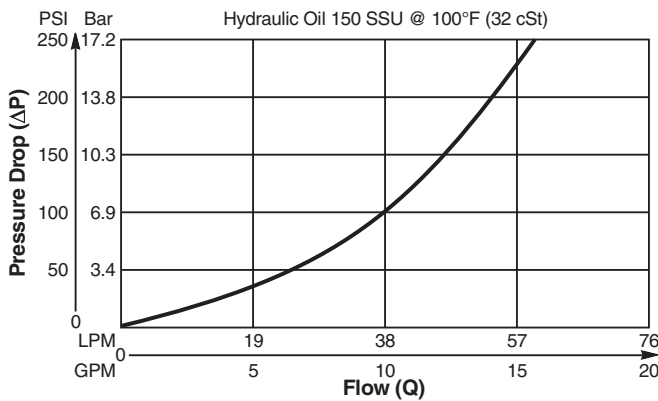

**Dimensions** Millimeters (Inches)

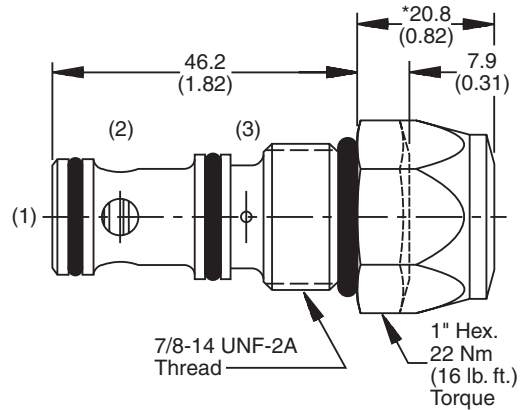

**Specifications**

<b>Rated Flow</b>	57 LPM (15 GPM)
<b>Maximum Inlet Pressure</b>	240 Bar (3500 PSI)
<b>Leakage @ 150 SSU (32 cst)</b>	Port 1 to 2 82 cc/min. (5 in <sup>3</sup> /min.) @ 240 Bar (3500 PSI)
<b>Cartridge Material</b>	All parts steel. All operating parts hardened steel.
<b>Operating Temp. Range/Seals</b>	-45°C to +93.3°C (Polyurethane) (-50°F to +200°F)
<b>Fluid Compatibility/Viscosity</b>	Mineral-based or synthetic with lubricating properties at viscosities of 45 to 2000 SSU (6 to 420 cSt)
<b>Filtration</b>	ISO Code 16/13, SAE Class 4 or better
<b>Approx. Weight</b>	.14 kg (.30 lbs.)
<b>Cavity</b>	C10-3S (See BC Section for more details)
<b>Form Tool</b>	Rougher      NFT10-3SR Finisher      NFT10-3SF

**Ordering Information**

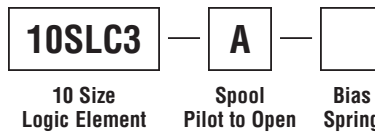

Code	Bias Spring
25	1.7 Bar (25 PSI)
50	3.5 Bar (50 PSI)
75	5.2 Bar (75 PSI)
*100	6.9 Bar (100 PSI)
*150	10.3 Bar (150 PSI)

\*Indicates larger cap height, see drawing.

**Seal Kit**  
WRK-10-3S



### General Description

Spool Type , Normally Open, Logic Element. This type is ideal for flow control functions. For additional information see Technical Tips on pages LE1-LE6.

### Features

- Hardened, precision ground parts for durability
- Polyurethane seals only
- No backup rings
- All external parts zinc plated

### Performance Curve

**Pressure Drop vs. Flow (Through cartridge only)**

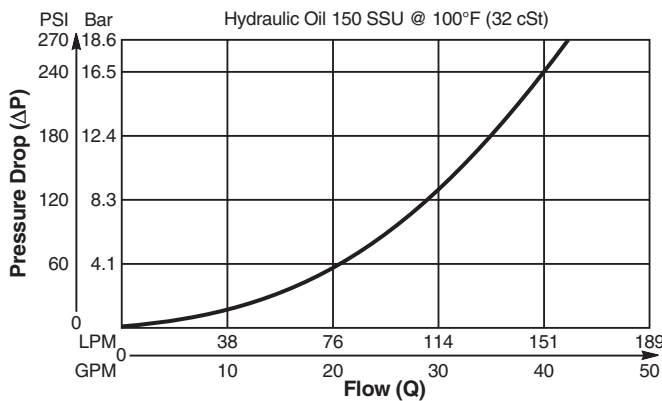

### Specifications

<b>Rated Flow</b>	189 LPM (50 GPM)
<b>Maximum Inlet Pressure</b>	240 Bar (3500 PSI)
<b>Leakage @ 150 SSU (32 cst)</b>	Port 1 to 2 82 cc/min. (5 in <sup>3</sup> /min.) @ 240 Bar (3500 PSI)
<b>Cartridge Material</b>	All parts steel. All operating parts hardened steel.
<b>Operating Temp. Range/Seals</b>	-45°C to +93.3°C (Polyurethane) (-50°F to +200°F)
<b>Fluid Compatibility/ Viscosity</b>	Mineral-based or synthetic with lubricating properties at viscosities of 45 to 2000 SSU (6 to 420 cSt)
<b>Filtration</b>	ISO Code 16/13, SAE Class 4 or better
<b>Approx. Weight</b>	.33 kg (.78 lbs.)
<b>Cavity</b>	C16-3S (See BC Section for more details)
<b>Form Tool</b>	Rougher      NFT16-3SR Finisher      NFT16-3SF

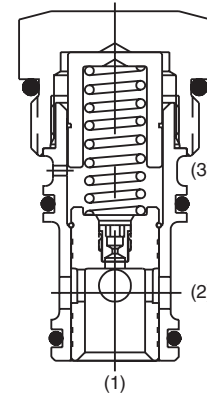
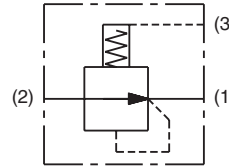

### Dimensions Millimeters (Inches)

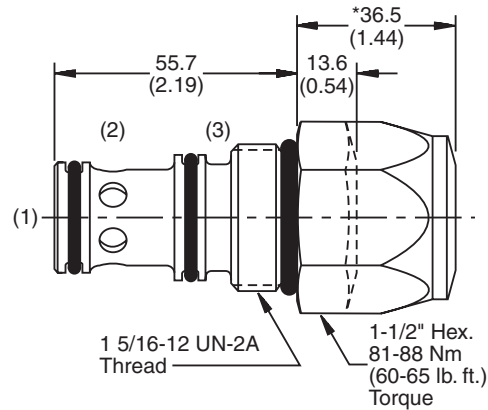

### Ordering Information

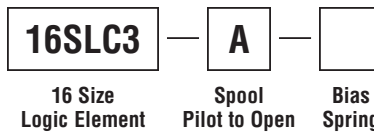

Code	Bias Spring
25	1.7 Bar (25 PSI)
50	3.5 Bar (50 PSI)
75	5.2 Bar (75 PSI)
*100	6.9 Bar (100 PSI)
*150	10.3 Bar (150 PSI)

\*Indicates larger cap height, see drawing.

**Seal Kit**  
WRK-16-3S

- CV**
- Check Valves
- SH**
- Shuttle Valves
- LM**
- Load/Motor Controls
- FC**
- Flow Controls
- PC**
- Pressure Controls
- LE**
- Logic Elements
- DC**
- Directional Controls
- MV**
- Manual Valves
- SV**
- Solenoid Valves
- PV**
- Proportional Valves
- CE**
- Coils & Electronics
- BC**
- Bodies & Cavities
- TD**
- Technical Data

**Technical Information**

- CV** Check Valves
- SH** Shuttle Valves
- LM** Load/Motor Controls
- FC** Flow Controls
- PC** Pressure Controls
- LE** Logic Elements
- DC** Directional Controls
- MV** Manual Valves
- SV** Solenoid Valves
- PV** Proportional Valves
- CE** Coils & Electronics
- BC** Bodies & Cavities
- TD** Technical Data

**General Description**

Spool Type , Normally Open, Vent to Close Logic Element. For additional information see Technical Tips on pages LE1-LE6.

**Features**

- High flow capacity
- Used as high flow switching or metering element
- Can be used for inline pressure compensated flow control when used with restrictor (refer to application)
- More stable than poppet type
- Various switching pressures available
- 1:1 pilot ratio
- Hardened working parts for maximum durability
- All external parts zinc plated

**Performance Curve**

**Pressure Drop vs. Flow (Through cartridge only)**

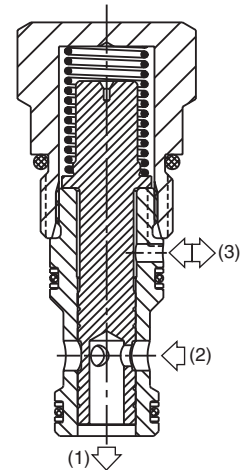
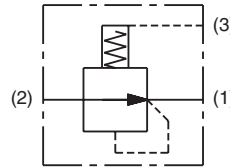
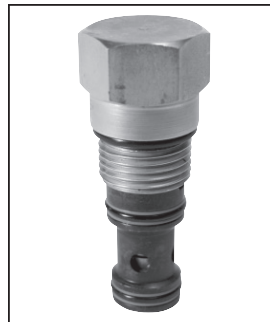
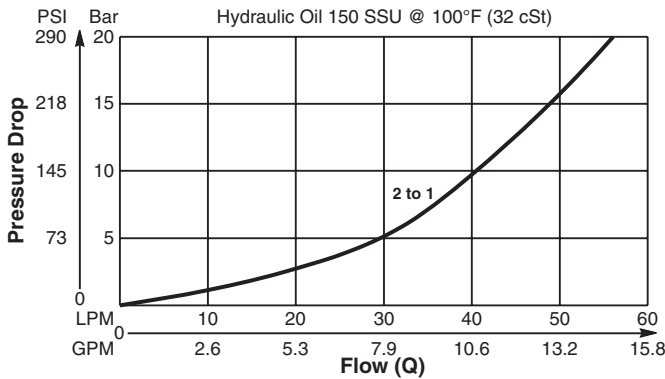

**Dimensions** Millimeters (Inches)

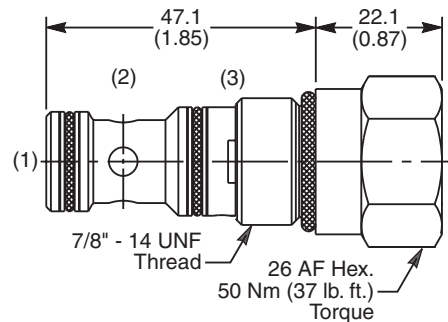

**Specifications**

<b>Rated Flow</b>	58 LPM (15 GPM)
<b>Nominal Flow @ 7 Bar (100 PSI)</b>	35 LPM (9.2 GPM)
<b>Maximum Inlet Pressure</b>	420 Bar (6000 PSI)
<b>Leakage @ 150 SSU (32 cst)</b>	50 ml/min. @ 100 Bar (1450 PSI)
<b>Switching Press.</b>	See ordering information
<b>Cartridge Material</b>	All parts steel. All operating parts hardened steel.
<b>Operating Temp. Range/Seals</b>	-40°C to +93.3°C (Nitrile) (-40°F to +200°F) -31.7°C to +121.1°C (Fluorocarbon) (-25°F to +250°F)
<b>Fluid Compatibility/Viscosity</b>	Mineral-based or synthetic with lubricating properties at viscosities of 45 to 2000 SSU (6 to 420 cSt)
<b>Filtration</b>	ISO Code 16/13, SAE Class 4 or better
<b>Approx. Weight</b>	.14 kg (.31 lbs.)
<b>Cavity</b>	C10-3S (See BC Section for more details)
<b>Form Tool</b>	Rougher NFT10-3SR Finisher NFT10-3SF

**Ordering Information**

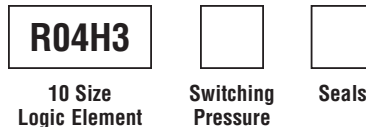

Code	Switching Pressure Non Adjustable Preset
1.0	1.0 Bar (14.5 PSI)
5.0	5.0 Bar (73 PSI) Std.
10.0	10.0 Bar (145 PSI)
15.0	15.0 Bar (218 PSI)
20.0	20.0 Bar (290 PSI)

Code	Seals / Kit. No.
N	Nitrile, Buna-N (Std.) / (SK30504N-1)
V	Fluorocarbon / (SK30504V-1)

*If no switching pressure is specified, valve will be supplied as R04H3-5.0N*

**General Description**

Spool Type , Normally Open, Vent to Close Logic Element. For additional information see Technical Tips on pages LE1-LE6.

**Features**

- High flow capacity
- Used as high flow switching or metering element
- Can be used for inline pressure compensated flow control when used with restrictor (refer to application)
- More stable than poppet type
- Range of spring ratings available
- Integral 250 micron pilot flow filter
- 1:1 pilot ratio
- Hardened working parts for maximum durability
- All external parts zinc plated

**Performance Curve**

**Pressure Drop vs. Flow (Through cartridge only)**

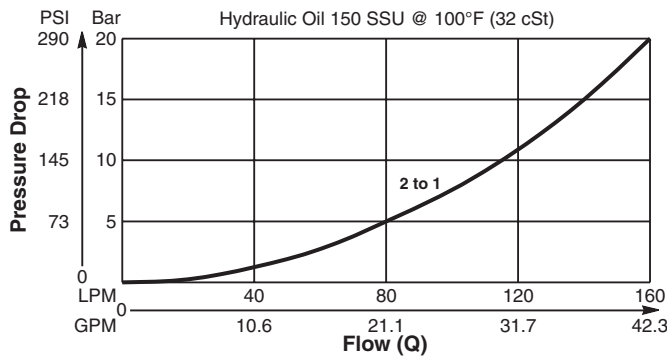

**Specifications**

<b>Rated Flow</b>	160 LPM (42 GPM)
<b>Nominal Flow @ 7 Bar (100 PSI)</b>	90 LPM (24 GPM)
<b>Maximum Inlet Pressure</b>	420 Bar (6000 PSI)
<b>Leakage @ 150 SSU (32 cst)</b>	125 ml/min. @ 100 Bar (1450 PSI)
<b>Switching Press.</b>	See ordering information
<b>Cartridge Material</b>	All parts steel. All operating parts hardened steel.
<b>Operating Temp. Range/Seals</b>	-40°C to +93.3°C (Nitrile) (-40°F to +200°F) -31.7°C to +121.1°C (Fluorocarbon) (-25°F to +250°F)
<b>Fluid Compatibility/ Viscosity</b>	Mineral-based or synthetic with lubricating properties at viscosities of 45 to 2000 SSU (6 to 420 cSt)
<b>Filtration</b>	ISO Code 16/13, SAE Class 4 or better
<b>Approx. Weight</b>	.37 kg (.82 lbs.)
<b>Cavity</b>	C16-3S (See BC Section for more details)
<b>Form Tool</b>	Rougher NFT16-3SR Finisher NFT16-3SF

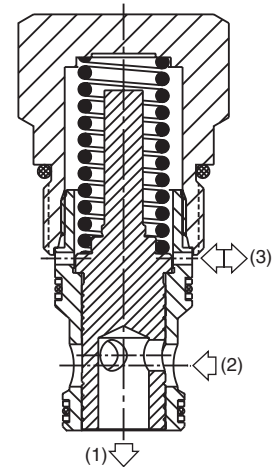
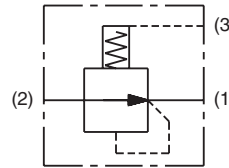
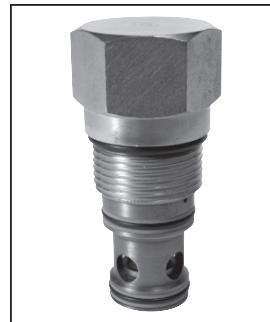

**Dimensions** Millimeters (Inches)

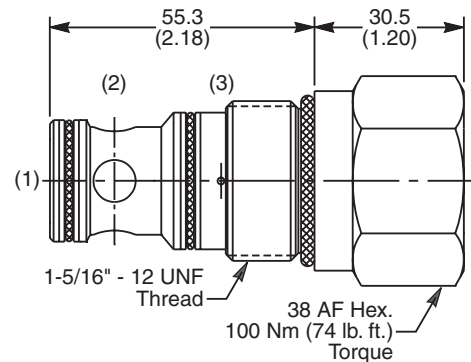

**Ordering Information**

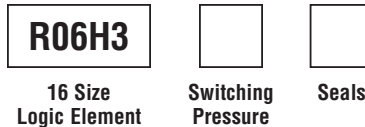

Code	Switching Pressure Non Adjustable Preset
1.0	1.0 Bar (14.5 PSI)
5.5	5.5 Bar (80 PSI) Std.
10.0	10.0 Bar (145 PSI)
15.0	15.0 Bar (218 PSI)
20.0	20.0 Bar (290 PSI)

Code	Seals / Kit. No.
N	Nitrile, Buna-N (Std.) / (SK30508N-1)
V	Fluorocarbon / (SK30508V-1)

*If no switching pressure is specified, valve will be supplied as R06H3-5.5N*

- CV** Check Valves
- SH** Shuttle Valves
- LM** Load/Motor Controls
- FC** Flow Controls
- PC** Pressure Controls
- LE** Logic Elements
- DC** Directional Controls
- MV** Manual Valves
- SV** Solenoid Valves
- PV** Proportional Valves
- CE** Coils & Electronics
- BC** Bodies & Cavities
- TD** Technical Data

**Technical Information**

- CV** Check Valves
- SH** Shuttle Valves
- LM** Load/Motor Controls
- FC** Flow Controls
- PC** Pressure Controls
- LE** Logic Elements
- DC** Directional Controls
- MV** Manual Valves
- SV** Solenoid Valves
- PV** Proportional Valves
- CE** Coils & Electronics
- BC** Bodies & Cavities
- TD** Technical Data

**General Description**

Spool Type, Normally Open, Vent to Close Logic Element. This type is ideal for pressure reducing functions. For additional information see Technical Tips on pages LE1-LE6.

**Features**

- Hardened, precision ground parts for durability
- Polyurethane seals only
- No backup rings
- All external parts zinc plated

**Performance Curve**

**Pressure Drop vs. Flow (Through cartridge only)**

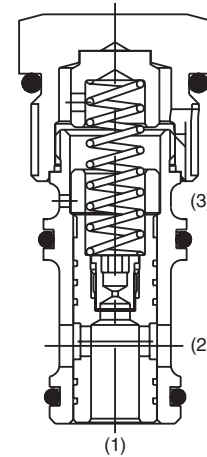
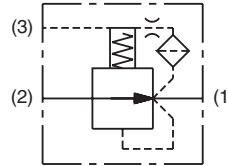
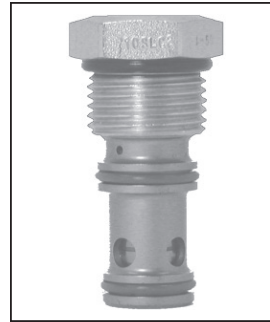
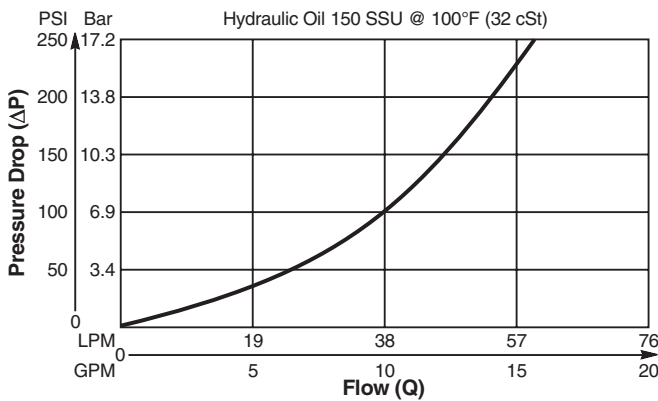

**Dimensions** Millimeters (Inches)

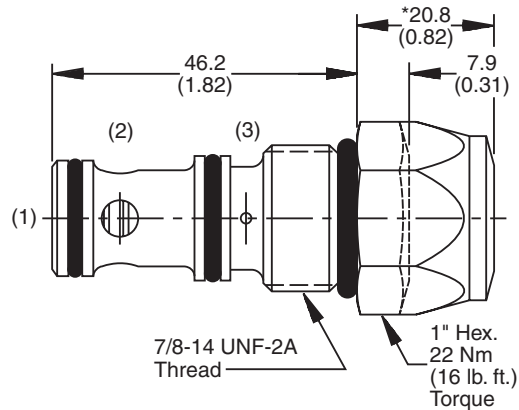

**Specifications**

<b>Rated Flow</b>	57 LPM (15 GPM)
<b>Maximum Inlet Pressure</b>	240 Bar (3500 PSI)
<b>Leakage @ 150 SSU (32 cst)</b>	Port 1 to 2 82 cc/min. (5 in <sup>3</sup> /min.) @ 240 Bar (3500 PSI)
<b>Cartridge Material</b>	All parts steel. All operating parts hardened steel.
<b>Operating Temp. Range/Seals</b>	-45°C to +93.3°C (Polyurethane) (-50°F to +200°F)
<b>Fluid Compatibility/Viscosity</b>	Mineral-based or synthetic with lubricating properties at viscosities of 45 to 2000 SSU (6 to 420 cSt)
<b>Filtration</b>	ISO Code 16/13, SAE Class 4 or better
<b>Approx. Weight</b>	.14 kg (.30 lbs.)
<b>Cavity</b>	C10-3S (See BC Section for more details)
<b>Form Tool</b>	Rougher      NFT10-3SR Finisher      NFT10-3SF

**Ordering Information**

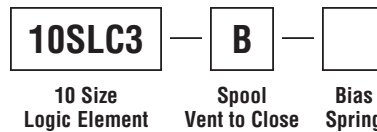

Code	Bias Spring
25	1.7 Bar (25 PSI)
50	3.5 Bar (50 PSI)
75	5.2 Bar (75 PSI)
*100	6.9 Bar (100 PSI)
*150	10.3 Bar (150 PSI)

\*Indicates larger cap height, see drawing.

**Seal Kit**  
WRK-10-3S

**General Description**

Spool Type , Normally Open, Vent to Close Logic Element. This type is ideal for pressure reducing functions. For additional information see Technical Tips on pages LE1-LE6.

**Features**

- Hardened, precision ground parts for durability
- Polyurethane seals only
- No backup rings
- All external parts zinc plated

**Performance Curve**

**Pressure Drop vs. Flow** (Through cartridge only)

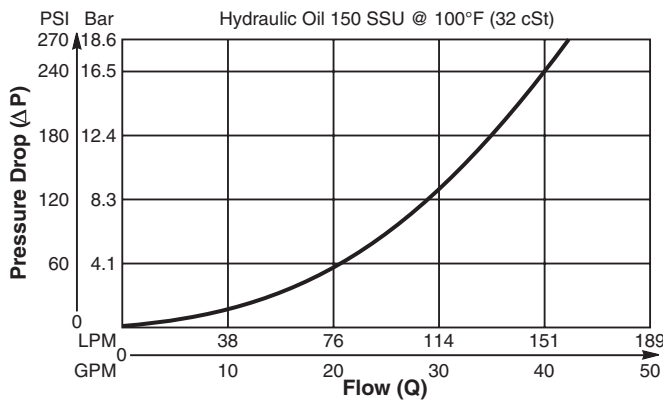

**Specifications**

<b>Rated Flow</b>	189 LPM (50 GPM)
<b>Maximum Inlet Pressure</b>	240 Bar (3500 PSI)
<b>Leakage @ 150 SSU (32 cst)</b>	Port 1 to 2 82 cc/min. (5 in <sup>3</sup> /min) @ 240 Bar (3500 PSI)
<b>Cartridge Material</b>	All parts steel. All operating parts hardened steel.
<b>Operating Temp. Range/Seals</b>	-45°C to +93.3°C (Polyurethane) (-50°F to +200°F)
<b>Fluid Compatibility/Viscosity</b>	Mineral-based or synthetic with lubricating properties at viscosities of 45 to 2000 SSU (6 to 420 cSt)
<b>Filtration</b>	ISO Code 16/13, SAE Class 4 or better
<b>Approx. Weight</b>	.33 kg (.78 lbs.)
<b>Cavity</b>	C16-3S (See BC Section for more details)
<b>Form Tool</b>	Rougher      NFT16-3SR Finisher      NFT16-3SF

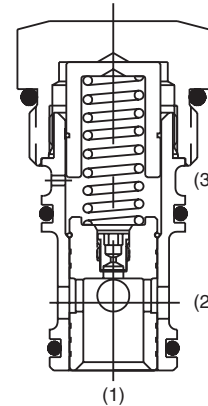
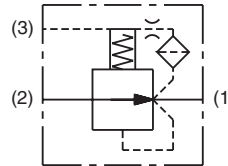
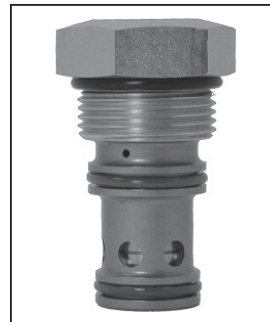

**Dimensions** Millimeters (Inches)

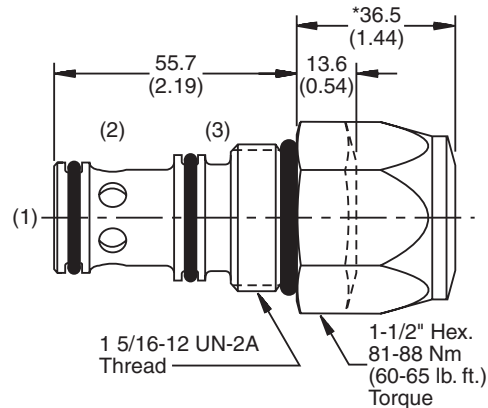

**Ordering Information**

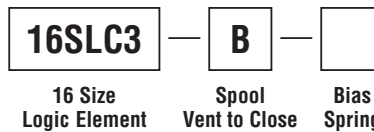

Code	Bias Spring
25	1.7 Bar (25 PSI)
50	3.5 Bar (50 PSI)
75	5.2 Bar (75 PSI)
*100	6.9 Bar (100 PSI)
*150	10.3 Bar (150 PSI)

\*Indicates larger cap height, see drawing.

**Seal Kit**  
WRK-16-3S

**CV**

Check Valves

**SH**

Shuttle Valves

**LM**

Load/Motor Controls

**FC**

Flow Controls

**PC**

Pressure Controls

**LE**

Logic Elements

**DC**

Directional Controls

**MV**

Manual Valves

**SV**

Solenoid Valves

**PV**

Proportional Valves

**CE**

Coils & Electronics

**BC**

Bodies & Cavities

**TD**

Technical Data

**Technical Information**

- CV** Check Valves
- SH** Shuttle Valves
- LM** Load/Motor Controls
- FC** Flow Controls
- PC** Pressure Controls
- LE** Logic Elements
- DC** Directional Controls
- MV** Manual Valves
- SV** Solenoid Valves
- PV** Proportional Valves
- CE** Coils & Electronics
- BC** Bodies & Cavities
- TD** Technical Data

**General Description**

Spool Type , Normally Open, Vent to Close Logic Element. For additional information see Technical Tips on pages LE1-LE6.

**Features**

- High flow capacity
- Used as high flow switching or metering element
- Can be used as pressure regulator with mainstage controlled remotely by a pilot relief valve or a proportional valve
- Various switching pressures available
- 1:1 pilot ratio
- Hardened working parts for maximum durability
- All external parts zinc plated

**Performance Curve**

**Pressure Drop vs. Flow (Through cartridge only)**

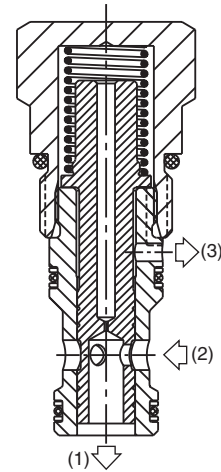
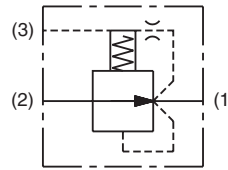
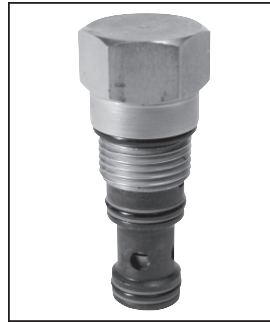
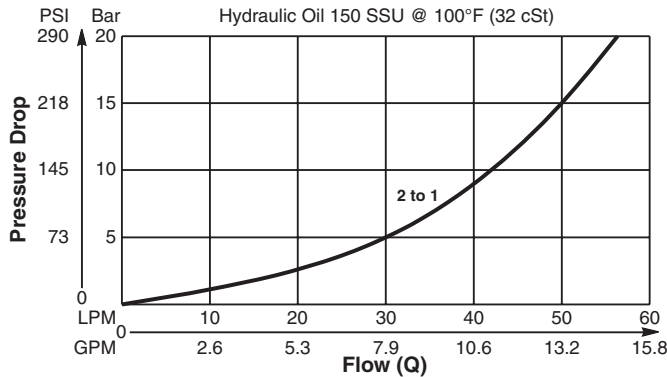

**Dimensions** Millimeters (Inches)

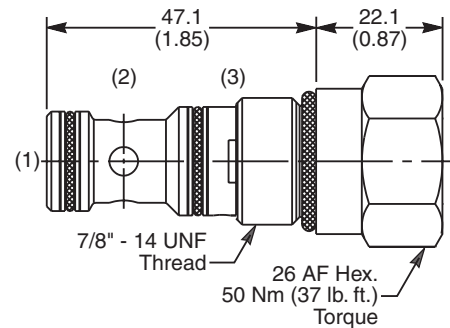

**Specifications**

<b>Rated Flow</b>	58 LPM (15 GPM)
<b>Nominal Flow @ 7 Bar (100 PSI)</b>	35 LPM (9.2 GPM)
<b>Maximum Inlet Pressure</b>	420 Bar (6000 PSI)
<b>Leakage @ 150 SSU (32 cst)</b>	50 ml/min. @ 100 Bar (1450 PSI)
<b>Switching Press.</b>	See ordering information
<b>Cartridge Material</b>	All parts steel. All operating parts hardened steel.
<b>Operating Temp. Range/Seals</b>	-40°C to +93.3°C (Nitrile) (-40°F to +200°F) -31.7°C to +121.1°C (Fluorocarbon) (-25°F to +250°F)
<b>Fluid Compatibility/Viscosity</b>	Mineral-based or synthetic with lubricating properties at viscosities of 45 to 2000 SSU (6 to 420 cSt)
<b>Filtration</b>	ISO Code 16/13, SAE Class 4 or better
<b>Approx. Weight</b>	.14 kg (.31 lbs.)
<b>Cavity</b>	C10-3S (See BC Section for more details)
<b>Form Tool</b>	Rougher NFT10-3SR Finisher NFT10-3SF

**Ordering Information**

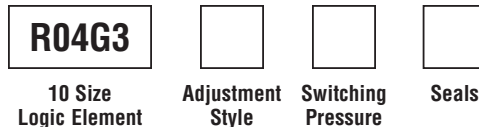

Code	Switching Pressure Non Adjustable Preset
1.0	1.0 Bar (14.5 PSI)
5.0	5.0 Bar (73 PSI) Std.
10.0	10.0 Bar (145 PSI)
15.0	15.0 Bar (218 PSI)
20.0	20.0 Bar (290 PSI)

Code	Seals / Kit. No.
N	Nitrile, Buna-N (Std.) / (SK30504N-1)
V	Fluorocarbon / (SK30504V-1)

*If no switching pressure is specified, valve will be supplied as R04G3-5.0N*



**Technical Information**

**General Description**

Spool Type , Normally Open, Vent to Close Logic Element. For additional information see Technical Tips on pages LE1-LE6.

**Features**

- High flow capacity
- Used as high flow switching or metering element
- Can be used as pressure regulator with mainstage controlled remotely by a pilot relief valve or a proportional valve
- Various switching pressures available
- Integral 250 micron pilot flow filter
- Hardened working parts for maximum durability
- All external parts zinc plated

**Performance Curve**

Pressure Drop vs. Flow (Through cartridge only)

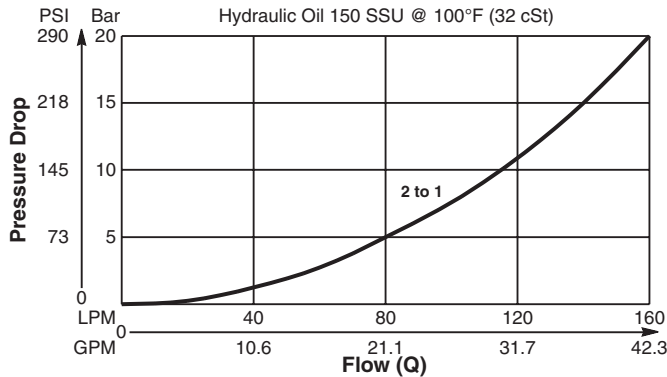

**Specifications**

<b>Rated Flow</b>	160 LPM (42 GPM)
<b>Nominal Flow @ 7 Bar (100 PSI)</b>	90 LPM (24 GPM)
<b>Maximum Inlet Pressure</b>	420 Bar (6000 PSI)
<b>Leakage @ 150 SSU (32 cst)</b>	125 ml/min. @ 100 Bar (1450 PSI)
<b>Switching Press.</b>	See ordering information
<b>Cartridge Material</b>	All parts steel. All operating parts hardened steel.
<b>Operating Temp. Range/Seals</b>	-40°C to +93.3°C (Nitrile) (-40°F to +200°F) -31.7°C to +121.1°C (Fluorocarbon) (-25°F to +250°F)
<b>Fluid Compatibility/ Viscosity</b>	Mineral-based or synthetic with lubricating properties at viscosities of 45 to 2000 SSU (6 to 420 cSt)
<b>Filtration</b>	ISO Code 16/13, SAE Class 4 or better
<b>Approx. Weight</b>	.38 kg (.84 lbs.)
<b>Cavity</b>	C16-3S (See BC Section for more details)
<b>Form Tool</b>	Rougher NFT16-3SR Finisher NFT16-3SF

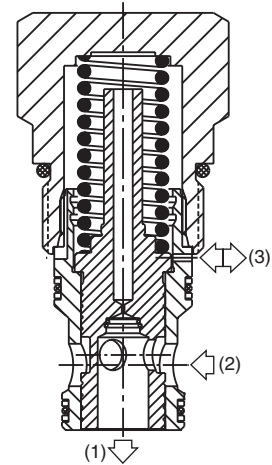
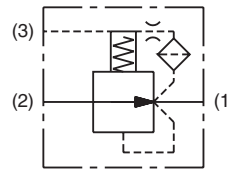
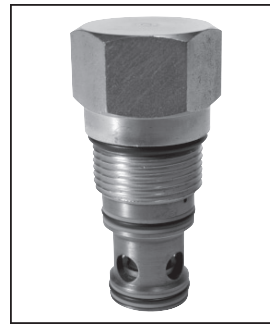

**Dimensions** Millimeters (Inches)

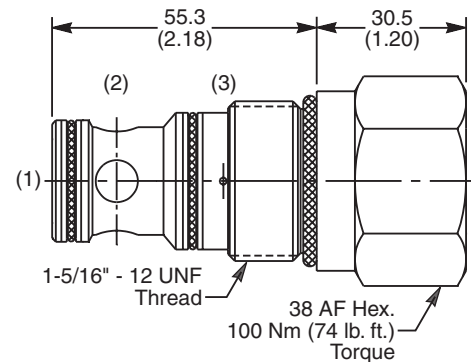

**Ordering Information**

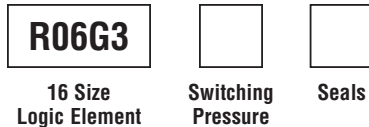

Code	Switching Pressure Non Adjustable Preset
1.0	1.0 Bar (14.5 PSI)
5.5	5.5 Bar (80 PSI) Std.
10.0	10.0 Bar (145 PSI)
15.0	15.0 Bar (218 PSI)
20.0	20.0 Bar (290 PSI)

Code	Seals / Kit. No.
N	Nitrile, Buna-N (Std.)/ (SK30508N-1)
V	Fluorocarbon / (SK30508V-1)

*If no switching pressure is specified, valve will be supplied as R06G3-5.5N*

- CV**
- Check Valves
- SH**
- Shuttle Valves
- LM**
- Load/Motor Controls
- FC**
- Flow Controls
- PC**
- Pressure Controls
- LE**
- Logic Elements
- DC**
- Directional Controls
- MV**
- Manual Valves
- SV**
- Solenoid Valves
- PV**
- Proportional Valves
- CE**
- Coils & Electronics
- BC**
- Bodies & Cavities
- TD**
- Technical Data